



BASIC TRAINING ON THE MANAGEMENT OF THE DEAD AND MISSING PERSONS

The background of the lower half of the cover features a faded, grayscale image of a disaster site with debris and people. A large, stylized orange arrow graphic, composed of five chevron shapes pointing right, is positioned to the left of the text 'TRAINING GUIDE'.

**TRAINING
GUIDE**

BASIC TRAINING ON THE MANAGEMENT OF THE DEAD AND MISSING PERSONS: TRAINING GUIDE

Copyright 2021

Local Government Academy (LGA)

Department of the Interior and Local Government (DILG)

In cooperation with:

NDRRMC - Management of the Dead and Missing Persons Cluster

All rights reserved.

This manual or any portion thereof may not be reproduced or used in any manner whatsoever without the express written permission of the Local Government Academy

ISBN 978-621-476-031-2 (Softbound/Paperback)

ISBN 978-621-476-032-9 (PDF)

Published by:

Local Government Academy

Department of the Interior and Local Government

8/F Agustin I Building, F. Ortigas Road (formerly Emerald Avenue) Ortigas Center, Pasig City, 1605 Philippines

Tel. No. (632) 8634-1906 / 8636 5847

www.lga.gov.ph



MANAGEMENT OF THE DEAD AND MISSING PERSONS TRAINING COURSE

I. BACKGROUND AND RATIONALE

In disaster management, most efforts are focused on the management of the survivors while very least considerations are given to the dead and the missing. Major disasters in the Philippines these past years recorded increasing numbers of dead and missing persons. In 2011, Tropical Storm Sendong (international name: Washi) struck the cities of Cagayan de Oro and Iligan in Southern Philippines, caused flash floods and landslides, with a total of 1,268 persons reported dead and hundreds missing. When Typhoon Pablo (international name: Bopha) made landfall in Mindanao in December 2012, the provinces of Davao Oriental and Compostela Valley were mostly affected causing landslide and massive flash floods, where a total of 1,067 persons were reported dead and hundreds were also reported missing. During Typhoon Yolanda (international name: Haiyan), the worst disaster ever to hit the country, it was reported that a total of 6,300 died and 1,785 missing.

In addition to these disasters, the Philippines also experienced human-induced disasters, such as the Zamboanga Siege in 2013 where 140 people died; 91 persons were confirmed killed and 48 persons still missing from the Cebu maritime disaster on 16 August 2013 where passenger vessel MV Thomas Aquinas collided with Cargo Vessel Express 7 of Sulpicio Lines. Fire razed the Kentex factory in Valenzuela City on 13 May 2015 where a total of 72 persons were killed, many of whom burned beyond recognition and disaster victim identification posed a major challenge. Most recently, 38 people died and 54 were wounded at the Resorts World Manila integrated resort following an attack in the early morning hours by a lone gunman who fired shots using an assault rifle and set fire to gambling tables. The situation can be classified as a complex emergency after the lone active shooter set the building on fire causing panic and causing the death by suffocation of most of the victims. Medics and firefighters could not enter the premises because the protocols then required that the active shooter must be neutralized first. The delays in proper response did not help the victims trapped inside the casino area.

The government plays a critical role in standardizing and guiding the tasks of handling dead bodies (retrieval, identification and final disposal), as well as missing persons and bereaved families, ensuring that legal norms are followed and guaranteeing that the dignity of the deceased and their families are respected, in accordance with their cultural and religious beliefs.

The approved NDRRMC Memorandum Circular No. 19, s. 2016 on the Rules and Regulations Governing the Implementation of the Management of the Dead and Missing Persons was used in the management of the dead and missing, as well as the bereaved families, during and after the Marawi Crisis. It was proven effective as to the principles and operationalization of the guidelines which provided clear perspectives in handling such unique operations. However, the lack of proper training and knowledge of key players and stakeholders also provided a major obstacle in

conducting the actual operations. With this, there is a need to train stakeholders and responders in the Management of the Dead and Missing Persons, which will highlight the core principles, features, roles and responsibilities, as well as functions of MDM at the national, regional, and local levels.

II. OBJECTIVES

General Objective

During the implementation of the training program, the participants will be able to acquire the knowledge, skill, and overall understanding that are essential in the policies and guidelines of the MDM in any disaster situation.

Specific Objectives

The participants will be able to:

1. Explain the importance of the management of the dead and missing as a system and mechanism during emergencies and disasters to the executives;
2. Identify the roles and responsibilities of each agency under the Management of the Dead and Missing Cluster;
3. Explain the process of handling dead bodies, gathering reports about missing persons, including bereaved families of the dead and missing;
4. Describe the process of reporting disaster casualties;
5. Apply the general principles of management of the dead and missing persons in a practical exercise;
6. Describe the MDM Cluster in the spectrum of Philippine Disaster Risk Reduction and Management System (PDRRMS), as one of the clusters in the National Disaster Response Plan (NDRP), and as an operational section in the Incident Management System (ICS);
7. Identify requirements, processes, protocols and other information related in handling dead bodies and body parts;
8. Identify different interventions available for the bereaved persons / families;
9. Describe mechanisms supporting MDM including over-all protocols, human resources development, networking and collaboration, reporting, communication, information management, logistics, monitoring and evaluation, research and development, and financing; and
10. Describe recommended actions needed during the pre-disaster state of DRRMCs – required organization, needed data, and procurement of equipment and other logistical support.

III. DURATION

- Three (3) days live-in training

IV. LEARNING METHODS AND TECHNIQUES

- Interactive-lecture discussion
- Workshops
- Structured exercises
- Demonstration/Return-demonstration

V. MODULE DESCRIPTION

MODULE	DESCRIPTION
Module 1: Rules and Regulations Governing the Management of the Dead and Missing Persons	This module is an introduction to the concepts and principles of Management of the Dead and Missing Persons (MDM) Cluster including its highlights, developments and key features. Further, it identifies key agencies needed to perform key activities in MDM.
Module 2: Management of the Dead and Missing as a Component to PDRRMS, NDRP, ICS and its Facilities	This module discusses the MDM Cluster in the spectrum of Philippine Disaster Risk Reduction and Management System (PDRRMS), as one of the clusters in the National Disaster Response Plan (NDRP), and as an operational section in the Incident Management System (ICS). The MDM Facilities and its functions are also presented in the module.
Module 3: Management of Dead Bodies and Body Parts	This module describes requirements, processes, protocols and other information related to handling dead bodies and body parts. It also highlights the required teams, strategies and methodologies in identifying dead bodies, including body parts. Further, the module explains the utilization of the Dead Body Information Form.
Module 4: Final Arrangement of the Dead	This module highlights the importance of proper final disposition of the dead (identified or unidentified) that is in accordance with cultural and religious beliefs. Likewise, this module highlights the procedures to be implemented by the MDM team.
Module 5: Management of Missing Persons	This module focuses on the importance of reporting missing persons associated with the disaster as this is a requirement in verification and validation. In addition, this module discusses strategies on retrieving information from key informants.

Module 6: Management of the Bereaved Persons / Families	This module highlights different interventions available for the bereaved persons / families. It also describes the institutional arrangement that supports the implementation of government programs related to families of casualties.
Module 7: System Support to Operations	This module describes mechanisms supporting MDM including over-all protocols, human resources development, networking and collaboration, reporting, communication, information management, logistics, monitoring and evaluation, research and development, and financing.
Module 8: Reportorial Requirements	This module discusses the importance of reporting disaster casualties; including processes and techniques in verifying and / or validating reports from the ground.
Module 9: MDM Field Manual	This module highlights the overall process of the MDM Cluster from its activation to the required support to the bereaved families / persons. Further, it identifies recommended actions needed during the pre-disaster state of DRRMCs – required organization, needed data, and procurement of equipment and other logistical support. Moreover, it highlights the protocols in setting up the required MDM facilities, reportorial requirements and MDM for infectious disease.

VI. TRAINING SCHEDULE

TIME	TOPIC
DAY 0	
02:00–04:00 PM	Arrival of Training Team and Participants
04:00–05:00 PM	Instructors Meeting: <ul style="list-style-type: none"> ● Preliminaries ● Rundown of training course flow ● Module assignments
05:00–06:00 PM	Venue Preparation

TIME	TOPIC
DAY 1	
08:00 – 8:30 AM	Registration Preliminaries/Opening Program <ul style="list-style-type: none"> ● Philippine National Anthem ● Invocation ● Message ● Expectations Setting ● Pre-Test
08:30 – 08:45 AM	Course Overview
08:45 – 09:00 AM	Health Break
09:00 – 10:00 AM	Module 1: Rules and Regulations Governing the Management of the Dead and Missing Persons
10:00 – 10:30 AM	Activity 1: MDM Organizational Structure
10:30 – 11:30 AM	Module 2: Management of the Dead and Missing as a Component to PDRRMS, NDRP, ICS and its Facilities
11:30 – 12:00 NN	Activity 2: MDM Facilities
12:00 – 01:00 PM	Lunch Break
01:00 – 01:20 PM	Activity 3: Lego Documentation
01:20 – 03:00 PM	Module 3.1: Handling Dead Bodies and Body Parts
03:00 – 03:15 PM	Health Break
03:15 – 04:15 PM	Activity 4: Getting Ready and Moving the Body
04:15 – 05:15 PM	Module 3.2: Handling Dead Bodies and Body Parts
05:15 – 05:30 PM	Daily Evaluation and Administrative Announcement

TIME	TOPIC
DAY 2	
08:00 – 08:15 AM	Preliminaries <ul style="list-style-type: none"> • Recap of Day 1
08:15 – 08:30 AM	Activity 5: Let's Volt-in
08:30 – 09:40 AM	Module 4: Final Arrangement of the Dead
09:40 – 10:00 AM	Activity 6: It's Complicated (Working Break)
10:00 – 11:30 AM	Module 5: Reporting Missing Persons
11:30 – 12:00 NN	Activity 7: Missing Person Form
12:00 – 01:00 PM	Lunch
01:00 – 03:00 PM	Module 6: Management of the Bereaved Persons
03:15 – 03:30 PM	Health Break
03:30 – 04:30 PM	Module 7: System Supports to Operations
04:30 – 05:30 PM	Module 8: Reportorial Requirements
05:30 – 05:45 PM	Daily Evaluation and Administrative Announcement

TIME	TOPIC
DAY 3	
08:00 – 08:30 AM	Preliminaries <ul style="list-style-type: none"> • Recap of Day 2 • Energizers
08:30 – 09:30 AM	Module 9: MDM Field Manual
09:30 – 10:00 AM	Activity 8: MDM Action Plan (Working Break)
10:00 – 12:00 NN	Simulation Exercise
12:00 – 01:00 PM	Lunch
01:00 – 02:00 PM	Simulation Exercise Synthesis
02:00 – 03:00 PM	Post Examination and Training Evaluation
03:15 – 03:30 PM	Health Break
03:30 – 04:00 PM	Closing Program <ul style="list-style-type: none"> • Impressions per Group • Response of Training Team • Closing Message • Distribution of Certificates
04:00 PM	End of training

MODULE 1

RULES AND REGULATIONS GOVERNING THE MANAGEMENT OF THE DEAD AND MISSING PERSONS

Module Objectives

At the end of this session, participants will be able to:

1. Know and understand the overview and basic concepts of the MDM Cluster
2. Explain the MDM policy statement and operational flow
3. Understand the MDM structure

DISASTER

A serious disruption of the functioning of a community or a society involving widespread human, material, economic, or environmental losses and impacts, which exceeds the ability of the affected community or society to cope using its own resources.

GENERAL EFFECTS OF DISASTER

- Casualty
- Damage to infrastructure
- Damage to production
- Disruption of lifestyle
- Loss of livelihood
- Disruption to essential services
- Damage to property
- Disruption to governmental systems
- Economic Loss
- Sociological & Psychological Effect

CASUALTIES

A person dead, missing, or injured due to an accident.

LEGISLATIVE REFORMS RELATED TO MDM

- 1930- Act No. 3753 Law on Registry of Civil Status
- 1949- Republic Act No. 386 An Act to Ordain and Institute The Civil Code of the Philippines
- 1975- Presidential Decree No. 651 "Requiring the Registration of Births and Deaths In The Philippines Which Occurred From January 1, 1974 And Thereafter"
- 1976- Presidential Decree No. 856, "The Code on Sanitation of the Philippines"
- 1991- RA 7160 Local Government Code of the Philippines
- 1993- Implementing Rules and Regulations of Act No. 3753 and other laws on Civil Registration
- 1996- Disposal of Dead Persons of the Code on Sanitation of the Philippines
- 2004- MC No. 2004-06 or the Issuance of Certificate of Death for the Burial of Amputated Part of a Human Body
- 2007- National Policy on the Management of the Dead and Missing Persons During Emergencies and Disasters

- 2010- RA 10121 Philippine Disaster Risk Reduction and Management Act of 2010
- 2011- MC No. 2011-02 or Revised IRR of PD 856 Chapter XXI (Disposal of Dead Person - "The requirement of a death certificate before burial may be waived in the case of special circumstances when the death certificate cannot be issued in time.
- 2012- NDRRMC 2nd Meeting on MDM Protocol
- 2014- NDRP National Disaster Response Plan / Cluster Approach
- 2015- OCD Operation Manual for Response
- 2016- NDRRMC MC 19-2016 Rules and Regulations Governing the Implementation of the Management of the Dead and Missing Persons
PNP MC 2016-33, "Guideline on the Recording, Monitoring, and Investigation of Missing and Found Persons, and Identification of Human Remains"

PURPOSE

1. Coordination and collaboration
2. Efficiently, timely and well-coordinated actions
3. Resource sharing mechanism

GENERAL POLICY

- The inherent dignity of the dead shall always be observed (e.g. unidentified and unprocessed human remains shall never be cremated nor buried in mass graves).
- Shall allocate / appropriate at least 1% of DRRM funds for MDM operations
- Efficient, timely and effective coordination shall be observed among and between all agencies and other stakeholders involved in MDM

GENERAL MEASURES

- Handling of human remains from retrieval, identification, and disposition in accordance with religious and culturally acceptable norms
- Must be carried out in a sanitary manner for the personal safety and protection of the responders and the general public
- Temporary storage facilities shall be established/provided and prepositioned in appropriate locations. Temporary burial sites shall be pre-identified by LGUs
- Final Disposition of dead bodies due to infectious diseases and CBRNE shall be done in accordance with the DOH recommended guidelines and procedures
- Reporting, communication and information shall be done accurately, systematically, and responsibly
- Physiological, social, psychological and medical needs, as well as assistance in processing of benefit claims of the bereaved families shall be attended to by the appropriate agencies

SUB-CLUSTER

- Disaster Victim Identification
- Management of the Bereaved Persons/Families
- Final Arrangement of the Dead/ Disposition of the Dead
- Management of the Missing Persons

INTEROPERABILITY OF MDM WITH SRR CLUSTER

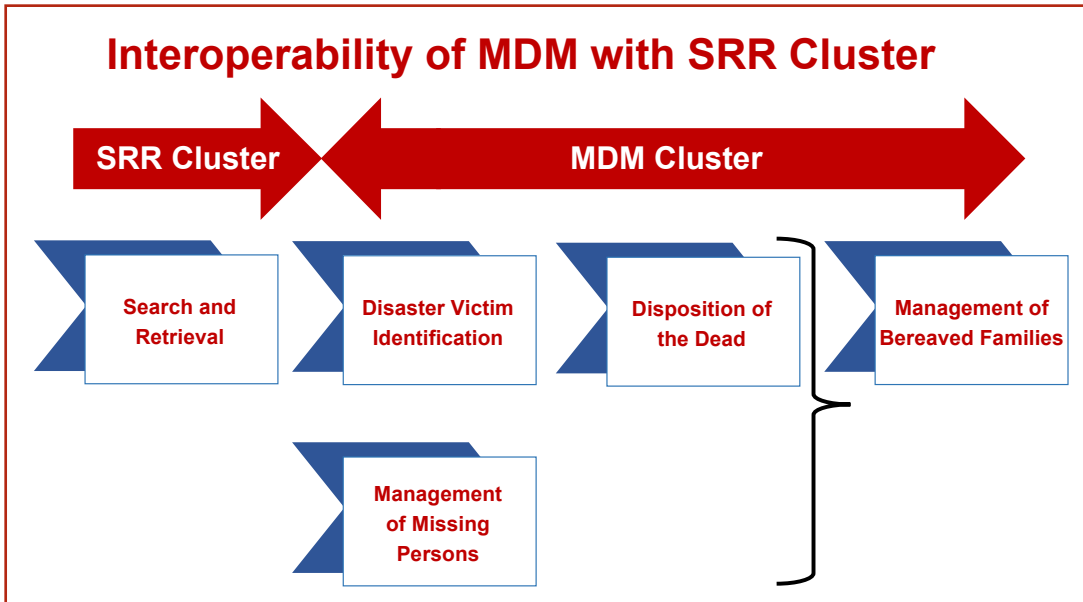

ORGANIZATIONAL / FUNCTIONAL CHART

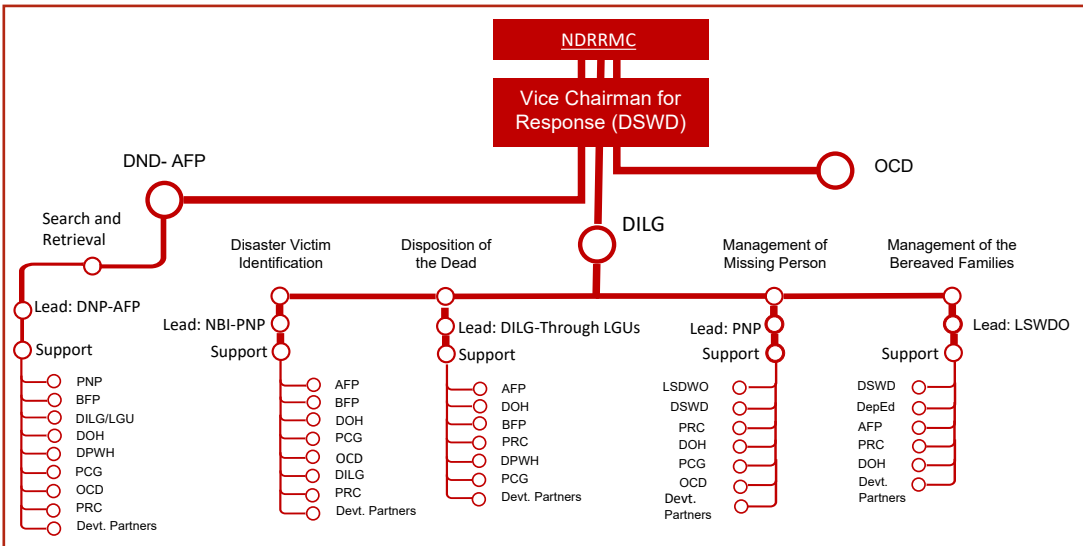

DISASTER VICTIM IDENTIFICATION (DVI)

NBI / PNP-FG

- Lead agency for DVI
- Accountable for the dead bodies caused by disasters (human-induced: PNP-FG; Natural: NBI) for identification and accounting
- Shall issue certificates
- Shall establish set of standards

LGU

- Responsible in reporting dead and retrieved bodies
- Provide essential information
- Authorize release of identified body to legitimate claimants in coordination with LHO
- Accountable for burying processes for unidentified bodies in coordination with NBI/PNP-FG
- Responsible for final disposition of unidentified bodies
- Assigned for identification of temporary burial sites
- Conduct seminars and trainings for proper handling of the missing and dead and bereaved families

LGU through LHO

- Gather reports submitted by NBI/PNP-FG and local hospitals
- Issue death certificate
- Assist the LGU for the release of dead bodies to legitimate claimants

DILG

- Allocate funds for the body movers during disasters, in case the LGUs are incapable.
- Submit reports

N/RDRRMC

- Provide official information on the dead bodies including an official list of identified and unidentified human remains.
- Utilize the existing Interpol forms.
- Receive the LGU reports through the RDRRMC Operation Centers which will be the basis of NDRRMC in providing information.

DISPOSAL / FINAL ARRANGEMENT OF DEAD: DILG THROUGH LGUs

LEGITIMATE CLAIMANTS

- The ultimate disposal of the identified and examined dead bodies shall be the responsibility of rightful claimants.
- Embalming of the dead bodies is subject to the decision of the legitimate claimants.

FOREIGN EMBASSIES

- Repatriation of identified and examined dead bodies of foreigners are the responsibility of the respective embassies.

LGU

- Accountable for final disposition of unidentified bodies to be buried, with consultation to the community and religious leaders.
- Collective or individual graves shall be properly labeled.
- Ensure adequate supply of cadaver bags compliant with guidelines of DOH.
- Authorize to release the identified human remains to the legitimate claimants.

LGU through LHO

- Shall observe the process of exhumation of dead bodies, ensuring proper disinfection of the area.

OCD

- Shall supplement the supply of cadaver bags of LGU

MANAGEMENT OF THE MISSING PERSON: PNP REQUIREMENTS

A person is considered missing upon reporting of the family or concerned citizen to the local police station.

VERIFICATION PROCESS

The PNP-FG and DSWD shall verify the identity of the reported missing persons from their records.

BASIS OF VERIFICATION OF REPORTED MISSING PERSONS

- PNP-FG - Records of Police Reports

VALIDATION/ CERTIFICATION REQUIREMENTS

- PNP-FG- Informs the Incident Commander who will be responsible for active search and rescue/retrieval and provides feedback
- LSWDO- Certify that missing person is affected by disaster
- PUNONG BARANGAY- Certify that the missing person resides in his/her jurisdiction.

REPORTING

- The list of missing persons presumed to be dead shall be submitted to the LCE for approval and endorsement to the RDRRMC.
- The LGU is also accountable for updating the list of missing persons and submitting reports to NBI/PNP-FG.
- RDRRMC will issue certificates of missing persons presumed to be dead due to the disaster.

P/C/MSWDO

- Establish the local social welfare inquiry desks
- Ensure available or alternative sources of information such as local census, voters list, i-cloud or backup servers with the support from regional or national DSWD
- Validate and process documents of the missing persons presumed to be dead during the disaster
- The DSWD, DOH, and PRC shall provide technical resource augmentation/assistance for the medical, psychological, and physiological needs of the families of the missing persons
- DOH shall ensure that the interventions are in accordance with IASC standards and guidelines

MANAGEMENT OF BEREAVED FAMILIES: LSWDO

Agency/Offices	Responsibilities
DSWD	Technical assistance and overall management assistance to P/C/MSWDO
DSWD, PRC, and NGOs	Augmentation of resource for physiological, social, and psychological needs to P/C/MSWDO
DOH and PRC	Resource augmentation for medical and psychological needs of the families of the missing person (until LGUs are ready and can provide)
DOH, DSWD, and PRC	Conduct of training program for responders in providing Mental Health and Psychosocial support to bereaved families
OCD Regional Offices	Coordination with the P/C/MSWDO for facilitating the requirements processing of the benefit claims of the bereaved families

DOCUMENT REQUIREMENTS NEEDED FOR BENEFICIARY CLAIM

- Barangay Certificate as resident and claimant is the legal beneficiary from the Punong Barangay.
- Police report of LDRRMC report from the local PNP/LDRRMC
- Death certificate from the local civil registrar
- Endorsement for payment from LDRRMC
- Endorsement of OCDRO to the chairperson of the NDRRMC

MODULE 2

MANAGEMENT OF THE DEAD AND MISSING PERSONS AS A COMPONENT TO PDRRMS, NDRP, ICS AND ITS FACILITIES

Module Objectives

At the end of this session, participants will be able to:

1. Understand the Management of the Dead and Missing (MDM) Persons Cluster as a component of Philippine Disaster Risk Reduction and Management System (PDRRMS), National Disaster Response Plan (NDRP) under Incident Command System (ICS);
2. Explain the concept of interoperability between the Search, Rescue, Retrieval (SRR) Cluster and MDM Cluster; and
3. Identify the MDM Facilities under the ICS Mechanisms;

MDM AND PDRRMS

OUR CHALLENGES

- Disasters remain a major challenge to achieve a disaster-resilient & safer community in the Philippines by 2020
- Natural hazards abound: typhoons, flood, landslide, earthquake, tsunami, volcanic eruption, drought, etc.
- Climate change remains a potential risk to the country
- Poverty, a vulnerability condition, prevails
- Fast growing population, increasing population densities, urbanization, environmental degradation and pollution increase disaster risks

REPUBLIC ACT 10121

RA 10121 transformed the PDRRMS from Disaster Relief and Response towards Disaster Risk Reduction and Management

Top-down and centralized disaster management	Bottom-up and participatory disaster risk reduction
Disasters as merely a function of physical hazards	Disasters mainly a reflection of people's vulnerability
Focus on disaster response and anticipation	Integrated approach to genuine social and human development to reduce disaster risk

INSTITUTIONALIZING DRRM

- RA 10121 transformed the PDRRMS from Disaster Relief and Response towards Disaster Risk Reduction and Management
- National Disaster Coordinating Council
- National Disaster Risk Reduction Management Council

NDRRM Framework

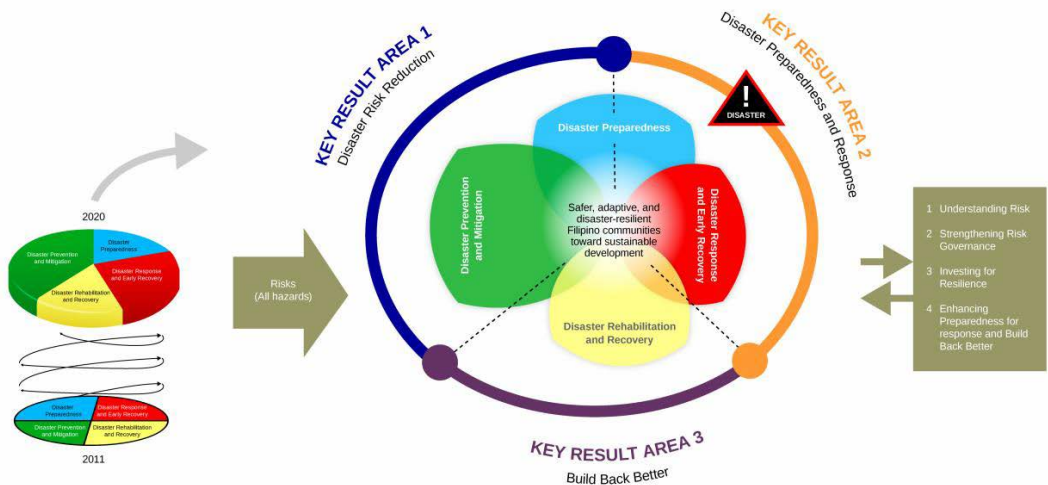

NDRRMC MEMBERSHIP

- Chairperson: Secretary, DND
- Vice Chairpersons
 - Secretary, DOST – Prevention and Mitigation
 - Secretary, DILG – Preparedness
 - Secretary, DSWD – Disaster Response
 - Director General, NEDA – Rehab and Recovery

DRRM COUNCIL NETWORKS

- 17 Regional Disaster Risk Reduction and Management Councils
- 81 Provincial Disaster Risk Reduction and Management Councils
- 146 City Disaster Risk Reduction and Management Councils
- 1,488 Municipal Disaster Risk Reduction and Management Councils
- 42,046 Barangay Disaster Risk Reduction and Management Committees

National Disaster Response Plan

Response Cluster

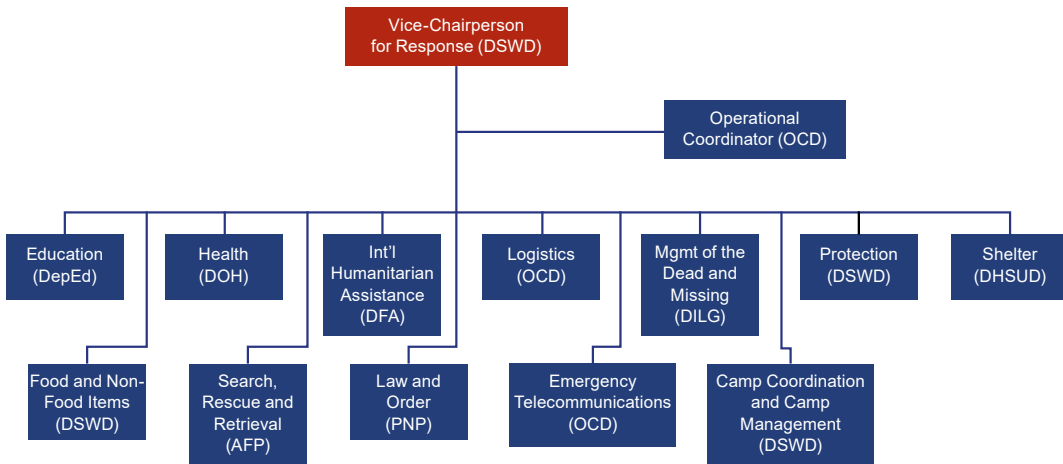

Organizational/Functional Chart in Support to MDM

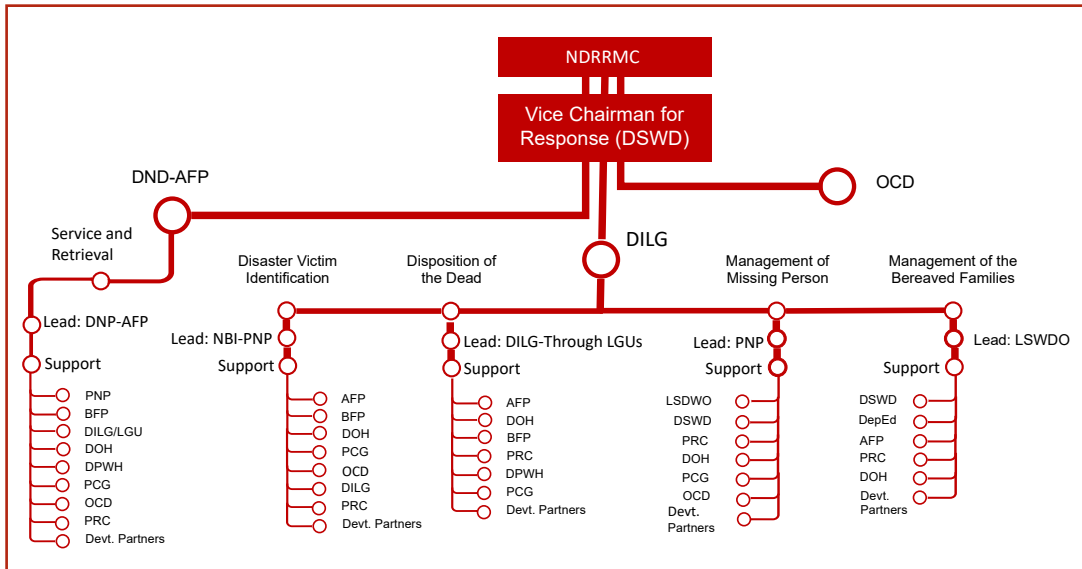

MDM AND ICS

DEFINITION OF ICS

ICS is a standard, on-scene, all-hazard incident management concept that can be used by all response groups.

ICS allows users to adopt an **integrated organizational structure** to match the complexities and demands of single or multiple incidents.

An IMT is composed of the **Incident Commander** and appropriate **Command and General Staff** personnel assigned to an incident.

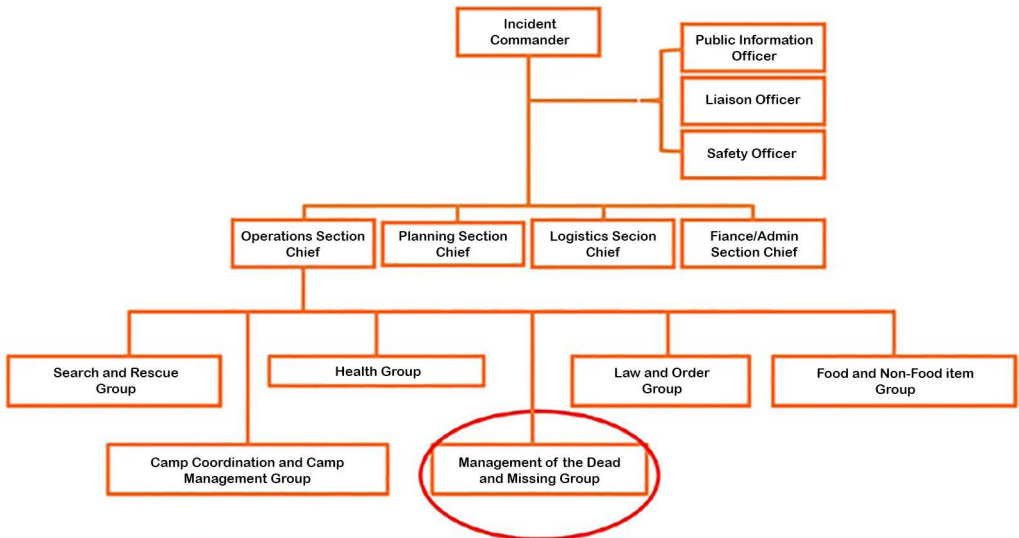
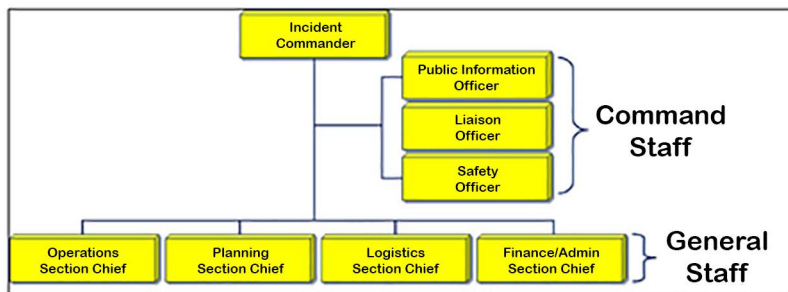

At the ground level, the Response Cluster resources act as responders under the IMT.

THREE ELEMENTS OF RESPONSE

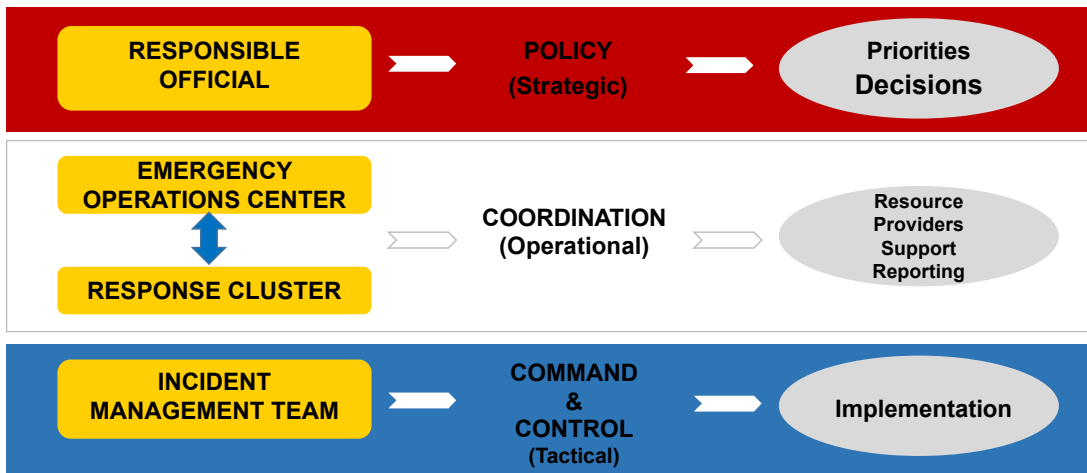

Organizational perspective, this chart shows how the MDM Functions works on the 3 elements of response shown in green boxes.

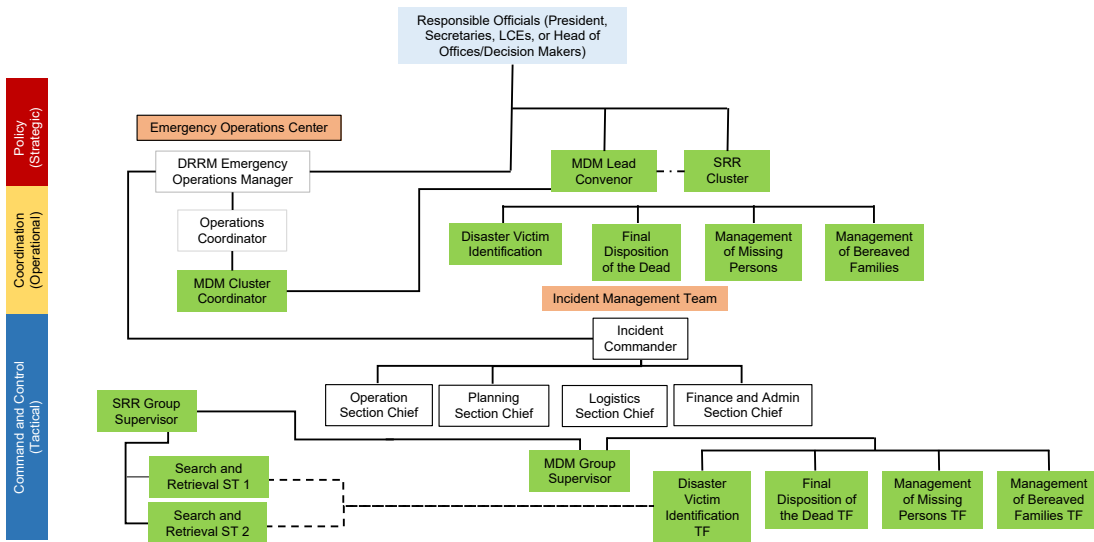

MDM FACILITIES

FACTORS TO CONSIDER WHEN ESTABLISHING ICS FACILITIES

- Needs of the incident
- Length of time the facility will be used
- Cost to establish the facility
- Environmental considerations

MDM FACILITY COMPONENTS

1. COLLECTION AREA

- Collection area is an open space that will be used for receiving human remains following their retrieval from the disaster site after an initial identification and documentation was made based on most available general features or other distinguishing features.
- The Collection Area is a facility to receive dead bodies that are being transferred without undergoing examination because family members have been able to identify them, making it possible to release them according to certain legal provisions. Collection Area is also used to facilitate identification of dead bodies.

General Guidelines:

- Place together the human remains in the collection area as they arrive from the recovery site.
- Ensure that the human remains' privacy is respected and placed out of the sun, to ensure that decomposition is slowed down.
- In tropical countries with high temperature: Refrigerate this area to avoid decomposition (a result of the injuries sustained).
- Arrange bodies according to their arrival to facilitate identification by classification.
- Place in predetermined spaces and classify by groups according to sex, skin color, and age.
- Classify also by biotype, color and length of hair, and by elements that require measurement, such as height and foot size, etc.

What it should have:

- Temporary Work Camps; and
- Areas for documentation and provisional filing of information

2. TEMPORARY MORGUE AREA

Temporary Morgue Area is a facility to place bodies while family members are in the process of completing the required documents and / or processes before they can take possession of the body because the remains have not been identified; or the body must be embalmed before being transported out of the country. This also serves as a temporary storage area of bodies and body parts.

General Guidelines:

- Recommended capacity should be 10 bodies per 10,000 population
- Preferred storage option is refrigerated containers with temperatures between 2°C to 4°C (35.6°F and 39.2°F).
- Each body or body part should be kept in a body bag or similar storage item before storage with waterproof labels or part in sealed places. **DO NOT WRITE DIRECTLY ON BODIES or BODY BAGS / SHEETS.**
- Staff should wear proper PPEs
- It should have a reception area and a room to store personal belongings and records.
- Refrigerated containers between 2°C and 4°C is the best method for prolonged storage and preservation of bodies, if none:
 - Protected room or environment that is as cold as possible
 - Refrigerated transport containers with individual racks used by commercial shipping companies
 - Use of ice should be avoided.
 - Depending on the type and magnitude of the disaster, the need for refrigerated containers should be expected. It is better to have mobile or portable refrigeration units like refrigerated trucks.

What it should have:

- Stainless steel postmortem tables or at least heavy duty trestle tables covered with plastic sheeting;
- Trolleys or stretchers for transporting bodies within the mortuary;
- Tarpaulin or plastic sheeting for the floor, if it is not made of concrete;
- Heavy duty black plastic sheeting for temporary screens;
- Cleaning materials: mops, buckets, cloths, soap, towels;
- Disinfectant and deodorizer;
- Protective clothing and heavy-duty rubber gloves;
- Translucent plastic bags 0.1mm thick and labels (if epidemic circumstances); and
- Proper drainage system

3. VIEWING AREA

Viewing Area is a designated facility where family members and others will view photographs except those photographs of body/body parts that are in the advanced stage of decomposition or any objects pertaining to the deceased and the body itself.

General Guidelines:

- Identification of the body should be given a high priority due to severe changes of the body after the retrieval.
- Designate a private viewing for the claimants
- Process or steps in identification should be:
 - Photographs of jewelry, clothing, or identifiable objects or features found in the examination of the human remains will be shown.
 - Photographs of the bodies and especially of the face if there are features that can help with identification will be shown.
 - The remains themselves are shown directly for visual recognition and to obtain the identification with ethical considerations and great care.
- Claimants should be psychologically prepared.

What it should have:

- Private room or area

4. ONE-STOP SHOP**a. DATA COLLECTION AREA**

Data Reconciliation Area provides storage of collected objects, pieces of evidence or property/ies, found at the disaster site. Ideally, the Data Reconciliation Center is established in the vicinity of the disaster area. A dedicated staff should prepare a master list of all found and registered objects and decide which objects are suitable for identification purposes.

General Guidelines:

- Evidence or property should be properly packed and stored.
- All collected objects should be processed and examined to determine their relevance to identification and classification.
- Photographs of collected objects are required for purposes of identification and matching.
- Ensure the preparation of records of collected objects.
- Separate the collected objects accordingly.
- Ensure the arrangement for return of property to owners or entitled recipients.

What it should have:

- Area to collect the information; and
- Private room or area

b. MISSING PERSON CENTER

Missing Person Center Provides care and restitution, and to process the collection and management of information on the missing including those presumed dead. The goal of the Missing Person Center is to ensure that the required information will be collected in a timely and an efficient manner to aid in the possible identification of retrieved unidentified bodies and status of missing persons.

- The local PNP is the lead agency in the over-all management of the missing persons augmented by the Department of Social Welfare and Development (DSWD) and supported by the:
 - Department of Interior and Local Government (DILG);
 - National Bureau of Investigation (NBI);
 - Philippine National Police Crime Laboratory (PNP-CL); Leagues and
 - Philippine Red Cross (PRC).

General Guidelines:

- The Missing Person Center is led by the Local PNP and being augmented by the Local Social Welfare and Development Office (LSWDO) and supported by various agencies.
- In line with the existing laws, the LSWDO shall establish the Social Welfare Inquiry Desk for data generation and information management of missing persons and their surviving families.
- The LSWDO shall ensure to have a list of those missing including information about them that will be used in identification of the dead bodies.
- Information collection shall be conducted by trained personnel.
- A consent should also be asked and any information will be classified as highly confidential and shall only be used for identification purposes.
- A data management system shall be established to make it easier for the comparison of the information on unidentified remains.

What it should have:

- Area to collect the information; and
- Private room or area

c. BEREAVED FAMILY HOLDING AREA

Bereaved Families Holding Area provided psychosocial support for the bereaved families which should be in a safe, accessible and comfortable place in the site.

General Guidelines:

- The LSWDO with augmentation and assistance from the supporting agencies shall be assigned in the overall management of the bereaved families.
- The LSWDO shall determine the assistance including physiological needs of the bereaved families, including:
 - Psychological Needs
 - Food Assistance
 - Financial Assistance
 - Livelihood Assistance
 - Clothing Assistance
 - Shelter Assistance
 - Management of the Orphans
 - Food/Cash for Work
 - Appropriate intervention must be identified by trained personnel.

What it should have:

- Area to collect the information; and
- Private room or area

The Provincial/City/Municipal Social Welfare Office (P/C/MSWDO):

- Assigned in the over-all management of the bereaved families,
- Responsible for the establishment of the Social Welfare Inquiry Desks for data generation/ information management of missing persons and their surviving families, and
- Parallel to the processes (information gathering), there shall be an ongoing psychosocial support for the bereaved families in the holding area established in a safe, accessible and comfortable place in the site.

5. TEMPORARY BURIAL/GRAVE SITE

Temporary Burial/Grave Site provides storage of the body. Following allocation of the unique body code, taking photographs and completion of the Dead Body Information Form, dead body, identified or unidentified, long-term temporary storage is needed and where it does not conflict with cultural norms.

General Guidelines:

- If there are small numbers of bodies: place in individual graves
- For larger numbers:
 - Place in trench graves, side by side, with at least 0.4 meters between bodies,
 - Each body, and each bag, needs to be individually labeled,
 - Record the location of the body, with its unique code, at the surface of the grave site, and on a plan of the whole burial site.
 - The measurements should be:
 - Length 2 meters
 - Width 2.5 feet
 - Depth 4 feet
- Each dead body or individual body part needs to be bagged separately and have its own unique code on waterproof labels attached to the body or body part as well as attached to the bag.
- Burial should be 1.5 m deep and at least 200 m from drinking water sources.
- Leave 0.4 m between bodies for trench burials.
- Lie bodies side-by-side in one layer only (not on top of each other).
- Clearly mark each body and mark their positions at ground level including the unique body code.
- Consider the option of burying bodies head-to-toe if required.
- Create a sketch map of the burial site recording the location of bodies using the unique code

Principle of Temporary Burial:

- Underground temperature is much lower than the atmospheric temperature, thus providing natural cooling, aiding in temporary preservation of dead bodies before final disposal;
- Depending upon the local conditions, modality of temporary burial for a short duration may only be adopted when there is complete absence of facilities for storage and proper preservation. However, temporary burial will not be used as a method of choice.

Guidelines for Temporary Burial:

- The site of temporary burial shall be carefully selected, secured for possible future exhumation and will be at least 250 meters away from the drinking water source.
- Bodies will be placed in parallel trenches and shall not be laid one on top of the other.
- Depth of burial will be at least 1.5 meters above the groundwater table, with at least 1 meter covering of soil and the distance between two bodies will be 0.5 meter.
- Each body must be buried in body bags or locally available material with its Individual Identification Number in a waterproof label. This number must be marked at the ground level and mapped for future reference in a register.
- Mass burial in a single ditch will not be used for storage and preservation.
- In mass fatality events that overextend local capacities, the authorities might not be able to quickly process remains in terms of data collection.
- In these cases, organized and respectful short-term storage to protect the remains as efficiently as possible needs to be established.
- Temporary burials can be considered.

Minimum Equipment



Stretchers



Leather Gloves



Rubber Gloves



Coveralls with Hood, Mask, and Eye Protector



Boots



Caps, soap, disinfectants and cloth

MODULE 3

HANDLING DEAD BODIES AND BODY PARTS

Module Objectives

At the end of this session, participants will be able to:

1. Identify the requirements in handling dead body and body parts;
2. Understand the Disaster Victim Identification Process; and
3. Develop appreciation through demonstration of the process in handling dead bodies to include processes, logistical requirements, culturally accepted norms and beliefs.

SEARCH, RESCUE, AND RETRIEVAL (SRR)

Search, Rescue, and Retrieval (SRR), as previously mentioned, is the first step in the identification of dead bodies. Activities start from the actual engagement and recovery of dead bodies from the impact area, and end when tagged/labelled and recovered body is turned over to proper agencies (NBI/PNP-FG) for DVI.

3 Major Phases on SRR

In the conduct of dead body and body parts recovery and retrieval, the Instructor must take note of 3 major phases being carried out by SRR teams:

1. Pre-operational

For Pre-operational phase, participants must be made aware of the main key activities being facilitated by SRR Team such as the following:

- a. Proper coordination from LGU; SRR should know, prior to recovering dead bodies, the pre-established temporary holding area set by the LGU;
- b. Preparation of Logistical supplies; The following items are vital in the recovery the SRR team must take in place such as PPE, Cadaver bags, supplies and tags, and administrative supplies (such as documentation from logbooks, pens, etc.)

Another layer which may be added to enforce safety and security of the retrieval teams if human-induced disasters occur. EOD and Medical to include k9 Teams will be needed to ensure safe and smooth retrieval operations, e.g. Marawi Crisis.

Team Composition	Primary Role
1 Team Leader	-Facilitates overall work performance of the team
1 Spotter	-Ensures safety and security of the SRR team members
1 Photographer	-Manages photographic documentation
1 Property Custodian	-Administer filing out of administrative documents and the preparation of tags and labels
1 Recorder	-Handles actual tagging and labeling of dead bodies/body parts
2 Body retrievers	

2. Operational

Once logistical supplies and other key activities mentioned in the pre-operational phase are secured, SRR teams are now set for recovery. For this phase, the following key activities must be take note of:

- a. Tagging and labeling;
- b. Photograph;
- c. Documentation;
- d. Transportation turnover of tagged dead body/body parts to DVI team; and
- e. Temporary holding area

3. Post Operational

Lastly, after the Operational Phase, the SRR team shall prepare and submit a report to the MDM Cluster.

REQUIREMENTS FOR DVI FLOW OF RETRIEVED BODY/BODY PARTS

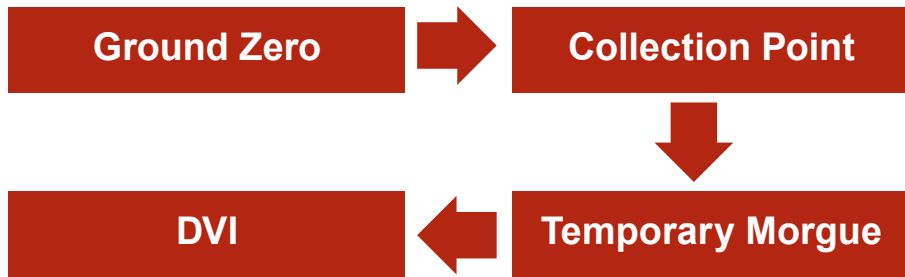

Levels of PPEs



Level A



Level B



Level C



Level D

MINIMUM EQUIPMENT

- Coverall
- Shoe Cover
- N95 Respirator
- Alcohol-based handrub
- Apron
- Gloves
- Goggles

CADAVER BAGS

Size specification

- standard 220 cm x 80 cm
- With stronghold carrying strap on each side
- Strap size is 1 1/2" width, approximately 26" length
- Strap color is white
- C-shaped opening with heavy duty zipper
- Zipper with lock
- Zipper size is 8"

Materials specification

- Heavy duty, non-porous, leak-proof plastic
- Color white

Pocket ID Specification

- With build-in identification pocket on the opposite side
- Thick transparent plastic
- Size is 8" in width, 10" in length
- With white zipper lock on top of pocket and white piping around the pocket

DILG Memorandum Circular No. 2016-139 dated October 3, 2016 "Updated Specification of Cadaver Bags for the Management of the Dead and Missing Persons"

TAGGING- DOUBLE TAGGING (BODY AND CADAVER BAG)

1. Location
2. Collector
3. Date of Collection
4. Body Number

Materials:

- Ziplock bag
- waterproof marker
- cardboard
- cable tie

TAGGING/LABELING

Team Location Body Number

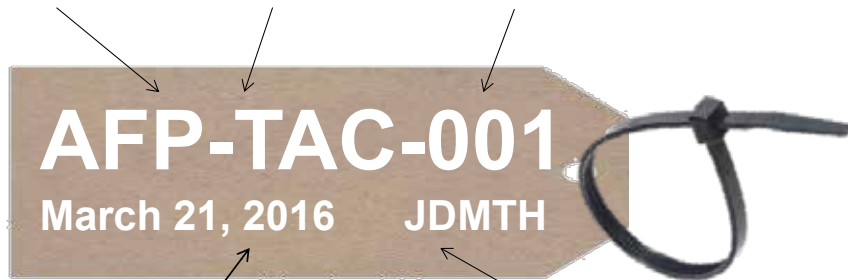

Date recovered Team leader Initial

TAGGING/LABELING PROPERTIES (DETACHED)

Property Team Location Body Number

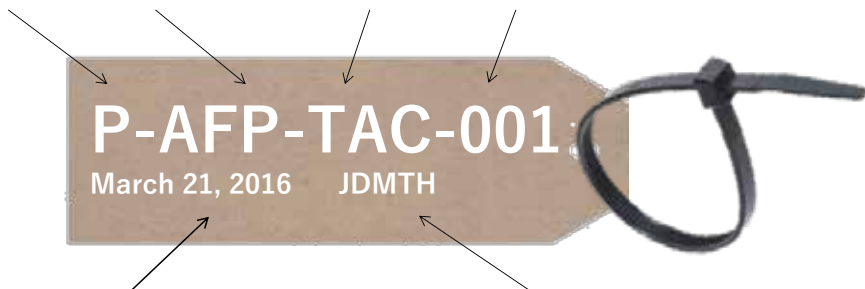

Date recovered Team leader Initial

Tagging per Area

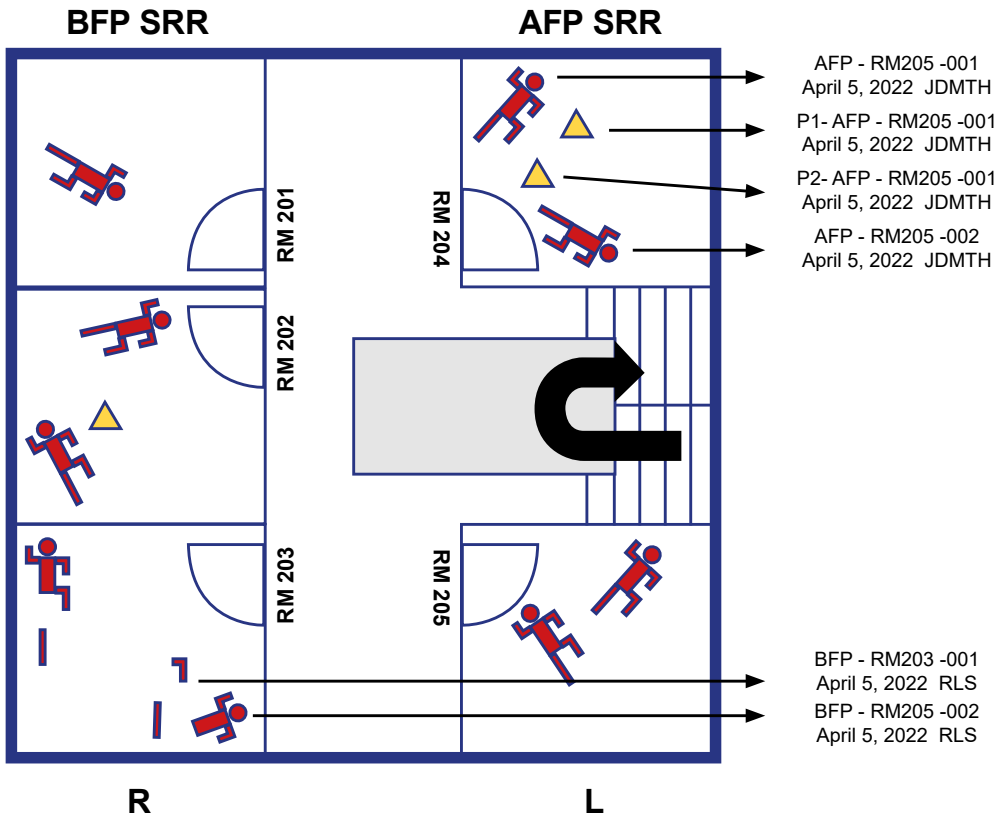

DOCUMENTATION

Recording/Note-taking of basic descriptions such as the following:

1. Sex
2. Age (child or adult)
3. Clothing (detailed description)
4. Personal belongings
5. Identifying marks

PHOTOGRAPH

To be Taken in 4 sections:

1. Overall view – general view of the disaster site
2. Midrange view – body with nearby references
3. Close-up view – whole body
4. Extreme Close-up view – face

To be taken in 4 sections:

- The full length of the body, front view (Fig. 5.1)
- The whole face, front view (Fig. 5.2)
- Any obvious distinguishing features (Fig. 5.3 – Fig. 5.5)
- All clothing or other items being worn e.g. bracelets (Fig. 5.2 – Fig. 5.5)
- A ruler or a scale, preferably.



Fig. 5.1



Fig. 5.2

Fig. 5.3

Fig. 5.4

Fig. 5.5

TRANSPORTING THE BODY

The transportation/ removal of bodies considers the following guidelines:

- Locate the body at the disaster site;
- Mark and document the situation in which body is found;
- Complete the evidence list in the recovery documentation, including entry of the body recovery number;
- Label and pack property BUT evidence-preserving packing of large objects (e.g. luggage items) is not required;
- Identify such objects using evidence tags instead;
- Locate and collect the personal effects of victims in the extended surroundings of the disaster site (e.g. hotel rooms, etc.);
- These items must also be listed in an evidence list provided with the recovery documents;
- The receipt/transfer of personal effects is recorded in a receipt/transfer record signed by the receiving and transferring parties in order to preserve the “chain of custody”; and
- Forward received personal effects to the Collection Center, accompanied by the evidence list and the receipt/transfer record.

CHAIN-OF-CUSTODY FORM

For chain of custody, every transmission, transferring or receiving of records shall be documented properly. Chain of custody form include the details of the dead body, including location of collection, number of cadavers retrieved, date and time, the person who turned over the dead body or the date, agency, signature, name of cadaver if there is any, identification code, and other remarks.

National Disaster Risk Reduction and Management Council MANAGEMENT OF THE DEAD AND MISSING PERSONS CLUSTER CHAIN OF CUSTODY FORM			
Location of Collection		_____	
No. of Cadavers Retrieved		_____	
Date and Time		_____	
Turned Over By	Received By	_____	_____
Agency	Agency	_____	_____
Date and Time	Date and Time	_____	_____
Signature	Signature	_____	_____
Turned Over By	Received By	_____	_____
Agency	Agency	_____	_____
Date and Time	Date and Time	_____	_____
Signature	Signature	_____	_____
Turned Over By	Received By	_____	_____
Agency	Agency	_____	_____
Date and Time	Date and Time	_____	_____
Signature	Signature	_____	_____
Turned Over By	Received By	_____	_____
Agency	Agency	_____	_____
Date and Time	Date and Time	_____	_____
Signature	Signature	_____	_____
Turned Over By	Received By	_____	_____
Agency	Agency	_____	_____
Date and Time	Date and Time	_____	_____
Signature	Signature	_____	_____
Turned Over By	Received By	_____	_____
Agency	Agency	_____	_____
Date and Time	Date and Time	_____	_____
Signature	Signature	_____	_____

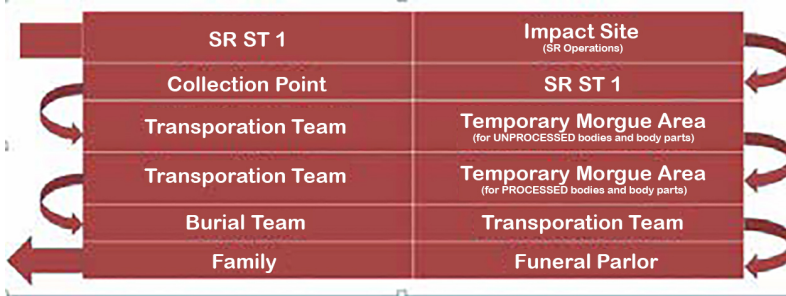

DISASTER VICTIM IDENTIFICATION PROCESS

IMPORTANT DEFINITION

Disaster Victim Identification, or DVI, is the method used to identify victims of mass casualty incidents, either man-made or natural. The objective is to continually promote utilization of a single protocol in identifying dead victims among international responders during mass disasters (INTERPOL Guidelines).

Post-mortem or PM data: The human remains are examined by specialists to detect forensic evidence to help identify the victim. This can include:

- Fingerprints
- Autopsy
- Odontology
- DNA profiling
- Physical indications

Ante-mortem or AM data: Dental and medical records, fingerprints and DNA are recovered from the victims' homes or provided by family members.

PHASE OF DVI



DISASTER VICTIM IDENTIFICATION (DVI) PROCESS FLOW

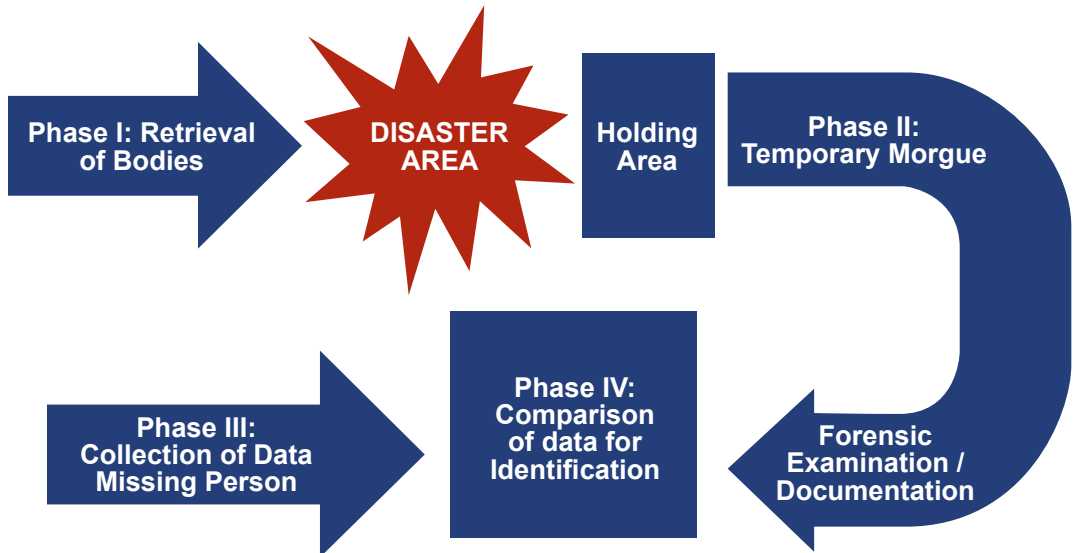

DVI COMMAND STRUCTURE AND RESPONSIBILITIES

- Structural command arrangements for DVI need to be established
- Requires defined reporting channels
- Ensure that effective liaison

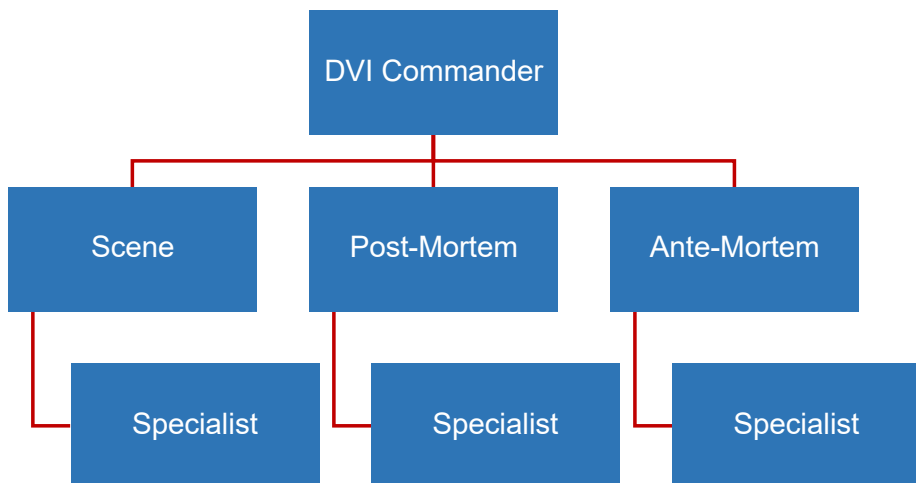

IMPORTANT DEFINITION

DVI Commander role:

- Phase 1: Scene Coordination
- Phase 2: Post-Mortem Coordination
- Phase 3: Ante-Mortem Coordination
- Phase 4: Reconciliation Coordination

Specialist role:

- Forensic Pathologist/Medico-Legal Officer
- Forensic Odontologist/Dentist
- Fingerprint Experts
- DNA Analyst
- Forensic Anthropologists
- Other key disciplines (photographers, radiologist, etc)
- Support Staff (Mortician, Encoder, Evidence Custodian, etc)

DVI PROCESS

>The DVI Process

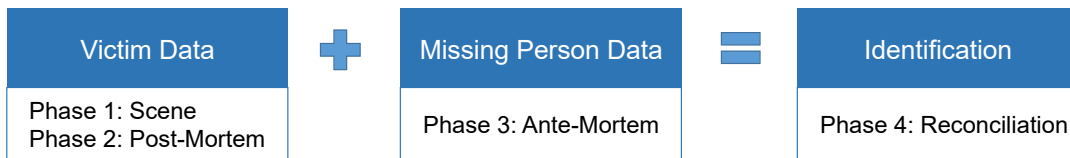

DVI FORMS

PHASE 1 - SCENE

The first step in the identification of dead bodies (DVI)

Activity starts from the....

- recovery/retrieval of the first responders to a dead body,
- proper tagging and documentation,
- to the turnover to the proper agencies for the clinical identification process.

Depending on the incident, and where it happened, it can take days or even weeks for all the victims and their property to be recovered.



PHASE II- POST-MORTEM

- The human remains are examined by forensic specialists to include properties to help identify the victim
- Conduct of Forensic Examinations
 - Fingerprint
 - Odontology
 - DNA
 - Autopsy
- Use of DVI PM (Pink) Form
- Establish Temporary Mortuary
- Visual identification is not considered to be accurate

PHASE III- ANTE-MORTEM

- Establish Ante Mortem Data Collection Center or Missing Person Center
- Retrieve, analyze and collate information on missing persons
- Collects standards next-of-kin (DNA)
- Recover Ante Mortem Properties
- Use DVI AM (Yellow) Form

PHASE IV- RECONCILIATION

- Once the PM and AM data are collected, a team of specialists compares and reconciles the two sets of information to identify the victims
- Establish Identification Board led by the DVI Commander
- Issue Certificate of Identification for identified victim

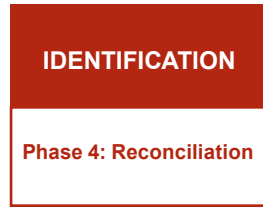



Use of Forensic Tools in the Identification of Dead Bodies

- Primary Identifiers:
 - Fingerprints,
 - Dental exam, and
 - DNA

1. FINGERPRINT ANALYSIS

Fingerprints are considered to be one of the best methods of identification because:

- Fingerprint are unique
- Fingerprint do not change
- Fingerprints can be classified

2. COMPARATIVE DENTAL ANALYSIS

Another effective tool for analysis

The unique structures and traits of human teeth and jaws readily lend themselves to use in the identification of living and deceased victims.

Dental data can be recovered and recorded at the time of post-mortem examination and compared to ante mortem data that are supplied by generalist and/or specialist dentists who treated the victim during their lifetime.

3. DNA ANALYSIS

A proven source of material used for identification because of the following reasons:

- A significant portion of the genetic information contained in a cell is unique to a specific individual and thus differs – except in identical twins - from one person to the next;
- DNA testing can be performed even on cases involving partial, severely decomposed remains;
- DNA matching is the best way to identify body parts;
- DNA analysis can be automated with a high throughput;
- DNA matching can be based on profiles from relatives, self-samples or belongings.

For a DNA profile, you need a sample taken from the deceased body or body parts and from the references. The samples will be sent to a laboratory and analyzed according to international standards and the profiles matched with respect to the source of reference.

Use of forensic tools/ identifiers in the identification of Dead bodies.

Secondary identifiers:

- Medical:
 - Tattoo, Scars,
 - significant deformities
- Physical effects:
 - articles, clothing, belongings

1. PERSONAL DESCRIPTION

It is important to remember that visual identification is not considered to be accurate.

- A personal description consists of basic data (age, gender, height, and ethnic affiliation)
- Tattoos, moles and disfiguration may also serve as indicators of identity

2. MEDICAL FINDINGS

- Medical findings, such as scars and surgical removal of organs may provide crucial information about a victim's medical history;
- Common types of surgery which exhibit few individual characteristics (e.g., appendectomy) must be taken into account in this context; and
- Unique numbers found on heart pace-makers and prosthetic devices are reliable identifying features.

3. EVIDENCE AND CLOTHING FOUND ON THE BODY

- This category includes all effects found on the bodies of victims (e.g. jewelry, articles of clothing, personal identification documents, etc.);
- Engraved items of jewelry may provide important clues to the identity of a victim. Items of jewelry have a higher identification value if they are firmly attached to a victim's body (e.g. piercing plugs or "ingrown" wedding rings).

4. IDENTIFIED BODIES

When the dead body was already identified based on sound judgment and supporting evidence, final arrangement must be done immediately.

PHASE V- DEBRIEFING

Feedback on the following:

- Planning
- Team Composition and Organization
- Execution
- Outcome

Disaster Victim Identification (DVI) Data Reporting Process

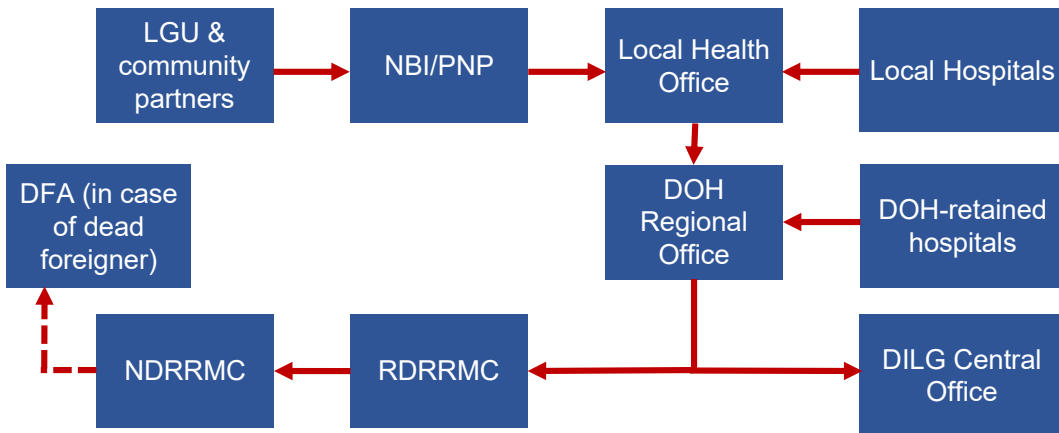

ISSUANCE OF CERTIFICATE

There are two (2) important certificates that the DVI teams issue –

1. Certificate of Identification

- Issued by medico-legal officers of NBI / PNP;
- For identified dead person; and
- Highlights identification

2. Certificate of Dead

- Issued by LHO, PNP and NBI;
- For identified dead person; and
- Highlights cause of death

**If the death is caused by human-induced disaster, the death certificate shall be provided by the PNP/NBI.*

MANAGEMENT OF RETRIEVED BODY PARTS AND CORPSES WAITING FOR EXAMINATION AND IDENTIFICATION

Specifically during mass-casualty incidents, it is important to have the following:

- a. Refrigeration is the preferred method of storing dead bodies and body parts.
- b. Process of applying formalin and quicklime to further preserve the body shall be done after the processing of NBI / PNP.
- c. Proper tagging of dead bodies should be observed and be temporarily buried in a collective grave (mono-layered), not more than 3 feet below the ground with plastic sheets beneath and above them.

MORTUARY FACILITY LICENSING

Normally, temporary burial areas are not a requirement if the number of corpses is manageable.

Storage can be a mortuary facility; however, to process corpses, he / she shall have training on MDM and in terms of facility, it should comply with the Sanitation Code.

1. The mortician shall undergo training on MDM before issuance of license provided by DOH.
2. Facility basic requirements of the mortuary shall meet the standards/guidelines based on the IRR of the Sanitation Code.

MODULE 4

FINAL ARRANGEMENT OF THE DEAD

Module Objectives

At the end of this session, participants will be able to:

1. Define the final arrangement of the dead;
2. Understand the organizational structure and identify the key offices/officers involved in the process;
3. Understand the guidelines on the final arrangement of the dead; and
4. Explain the procedures to be observed by the key actor/s in this process.

FINAL ARRANGEMENT OF THE DEAD

Final Arrangement of the Dead is the process of handling the body after complete documentation has been done by the DVI Team up to the turnover to the legitimate claimants (for the identified remains); or Temporary Burial (for the unidentified remains and those without claimants).

DEFINITION OF DEATH

Death is a permanent disappearance of all evidence of life at any time after live birth has taken place.

Legal Consequences of Death:

- a. Extinguishment of legal personality of the deceased
- b. Extinguishment of personal rights and obligations of the deceased (e.g criminal liability, obligation to perform a duty that is personal to the deceased)
- c. Transmittal of some of the real rights and obligations of the deceased (e.g transfer of ownership of property)
- d. Compel the other party to perform his/her/its obligation due to the death of the deceased.

The 3 types of disaster victims that are involved in the final arrangement of the dead

- a. Identified Human Remains
- b. Unidentified Human Remains
- c. Missing Persons (in relation to presumptive death)

TURNING OVER BODY / BODY PARTS

When the task of Search and Retrieval ends, retrieved bodies/ body parts are turned-over of to DVI teams at temporary holding area/temporary mortuary where each member of the DVI team accomplishes the Body Retrieval Form and records the transactions in a Turn-over Logbook to document the Chain of Custody.

To overcome the initial chaos in identifying victims, a structured search and discovery phase should be prepared in cooperation with the Evidence Collection Team, the Disaster Investigation Team and the Access Control and Security Team. This phase includes the search for bodies, property and evidence (which may also be used in the subsequent investigation into the causes of the disaster).

Wherever possible, responsibility for recovery and evidence collection operations should be placed in the hands of the police who might call on various specialists, such as odontologists and pathologists that are trained to recognize and differentiate human tissues as needed.

It is important to remember that matching of separate body parts should be performed only by authorized forensic medical experts, and not by the recovery personnel. Medical and dental experts should be at the scene to assist the police in collecting body parts and particularly bones and teeth.

The DVI Team follows the Recovery and Evidence Collection/Preservation Procedure that includes:

- Briefing and tasking process per sectoral assignment with respective sectoral operations commanders;
- Distributing of sketches or maps of the disaster area;
- Providing appropriate safety gear and clothing (helmets, overalls, boots, rubber gloves, etc.) to the operational personnel by the Recovery Command Centre including the necessary recovery documents for each body/body part and item of evidence
- Documenting the discovery site (description, photos, sketch or survey of the position of the body with the aid of GPS and/or crime scene surveying instrument);
- Taking photographic documentation of the body for recovery files and forensic medical examination;
- Attaching the recovery number to the body/body part. This number is used as the body reference number and remains affixed to the body/body part during the entire identification process.
- Completing the Interpol DVI Postmortem Form (pink), Part B, (Recovery Data), with reference to the recovery number
- Placing of the body/body part in a body bag; attachment of the recovery number to the outside of the body bag; sealing of the body bag;
- Removing the body/body part and transport it to the Recovery Command Centre;
- Preparing and compile recovery documents and submit documentation to the Recovery Command Center;
- Procuring new recovery documents as maybe needed; and
- Transferring the body/body part and recovery documents to the Recovery Command Centre.

LGU ROLES AND RESPONSIBILITIES

- Be responsible for the final disposition of the unidentified bodies to be buried in the collective or individual graves, marked with their unique case numbers and/ or labels.
- Consult the community and religious leaders of the disaster site regarding the final disposition of the unidentified bodies.
- Through the local health officials observe the exhumation of dead bodies with proper disinfection of the disinterment area.
- Acquire adequate supply of cadaver bags (compliant to the DILG MC 2016-139 Dated Oct 3, 2016)
- OCD shall augment the supply of cadaver bags of LGU
- Establish and preposition in appropriate locations temporary storage facilities within standard for human remains
- Pre-identify temporary burial sites shall be pre-identified by LGUs.
- Burial assistance program
- Special consideration shall be taken in determining the cause, date, place, and manner of death of the human remains.
- Whenever necessary, a medico-legal examination must be conducted to a cadaver.

Local Health Officer	Local Social Welfare Officer
Shall provide their contact information to the legitimate/rightful claimant	
Must maintain the confidentiality of all information, divulging any information only to the legitimate/rightful claimants of the remains*	
Shall report the list of casualties to the Local DRRMC, copy furnished DOH Regional Office	

IDENTIFIED VS UNIDENTIFIED REMAINS

Identified Remains - refer to those where a death certificate was issued.

Unidentified Remains - refer to those where death certificates cannot be issued.

LEGITIMATE VS RIGHTFUL CLAIMANTS

Legitimate Claimants

- Proof of filiation with the deceased must be established by the claimant.
- The claimants must be either of the following:
 - a. Spouse;
 - b. Children, legitimate or illegitimate;
 - c. Parents, legitimate or illegitimate;
 - d. Brothers and sisters, legitimate or illegitimate;
 - e. Other relatives; and
 - f. State in which the deceased was a citizen

Rightful Claimants

- The claimant must establish the following:
 - a. Proof of filiation with the deceased;
 - b. Obligated to give support;
 - c. Right to have custody over the human remains of the deceased;
 - d. Right and duty to prepare for the burial arrangement of the deceased; and
 - e. Rules of Preference on succession

- The following are the rightful claimants if the deceased is single (w/o a child):
 - a. Parent;
 - b. Brothers and sister;
 - c. Grand-parents;
 - d. Uncles and aunts;
 - e. Cousins;
 - f. Other relatives; or
 - g. State

- The following are the rightful claimants if the deceased is single (w/ a child):
 - a. Child;
 - b. Parent;
 - c. Brothers and sister;
 - d. Other relatives; or
 - e. State

- Rules of Preference
 - a. Legitimate over illegitimate relationship;
 - b. Spouse over ascendant;
 - c. Paternal over maternal;
 - d. If the descendant is of same degree or brothers and sister, the oldest shall be preferred;
 - e. Citizenship over country of residence

Not all legitimate claimants are considered as rightful claimants. However, all rightful claimants must be legitimate claimants.

Remember:

- Immediate Family over Collateral Relatives
- Legitimate Family over Illegitimate Family
- Legal Spouse over live-in partner or paramour
- Father over Mother
- Older relatives over younger relatives
- Paternal family over maternal relatives
- If legally adopted, adopter over natural parent
- If not legally adopted, natural parent over adopter

IDENTIFIED REMAINS WITH LEGITIMATE CLAIMANTS

Requirements for the claiming of the remains:

- **Primary Documents**

- Certified True Copy of Birth Certificate
- Certified True Copy of Marriage Contract (if claimant is married)

*Shari-a Law will be followed for Muslims

- **Secondary Documents (at least two):**

- Baptismal Certificate
- Barangay Certification (for residency or relationship of the claimant with dead person)
- Affidavit of Corroborating Individuals
- Pictures of the Victim/s
- Certification of Membership from Religious Organization

Burial / Cremation

Prior proceeding with the discussion on burial and cremation, it is important to underscore some key points in funeral for the deceased

Funeral

- The funeral shall be in accordance with the expressed wishes of the deceased. In the absence of such expression, his religious beliefs or affiliation shall determine the funeral rites. In case of doubt, the form of the funeral shall be decided upon by the person obliged to make arrangements for the same, after consulting the other members of the family (Article 307 of the New Civil Code).
- No human remains shall be retained, interred, disposed of or exhumed without the consent of the persons mentioned in articles 294 and 305 (Article 308 of the New Civil Code).

- Any person who shows disrespect to the dead, or wrongfully interferes with a funeral shall be liable to the family of the deceased for damages, material and moral (Article 309 of the New Civil Code).
- The person who is preferred in the right to make funeral arrangements may waive the right expressly or impliedly in which case the right and duty immediately descend to the person next in order.
- Expressed wishes of the deceased are given priority provided that it is not contrary to law, public policy, public morals, good customs, or prejudicial to a third person with a right recognized by law.

There are ways of disposing of the dead body which are either burial or through cremation. Although the ultimate disposal of dead bodies is the responsibility of the rightful claimants, there are processes and protocols which should be observed first, in accordance with the law

TEMPORARY BURIAL SITE

Area of Concern	Specification/s
Burial Site	Properly marked and accurately mapped indicating the body bags.
Bottom of the Grave/Pit	At least three (3) meter distant to the ground water table or not subject to seasonal high water table
Trenches	May be shallow or less than 1.8 meters (if post mortem examinations are forthcoming)
Arrangement of Body Bags	<ol style="list-style-type: none"> Buried in orderly rows of 10-20 Should be side by side and not piled up
Body Tags	Should include basic class information (sex, age, etc)
Remains	<ol style="list-style-type: none"> Photo documentation Clothing, jewellery and other personal effects are best left on the body. Can be exhumed later and a post-mortem examination performed even if the body is already markedly decomposed (even possibly skeletonized)

CREMATION

“Cremation is increasingly common but is prohibited for those who die from unnatural causes until it is certified that there is documentation of a thorough examination of the body, that any physical evidence necessary for resolving the case has been preserved, and the deceased has been accurately identified.”

Cremation of unidentified bodies should be avoided for several reasons:

- Cremation will destroy evidence for any future identification.
- Large amounts of fuel are needed (usually wood).
- Achieving complete incineration is difficult, often resulting in partially incinerated remains that have to be buried.
- It is logistically difficult to arrange for the cremation of a large number of dead bodies.

-Pan American Health Organization, 2016

CERTIFICATION

Certificate of Death

- The Issuance of Certificate of Death for the Burial of Amputated Part of a Human Body (MC No. 2004-06 of the Philippine Statistics Authority (PSA) provided guidelines about the Issuance of Certificate of Death for the Burial of Amputated Part of a Human Body)
- As provided in Rule 31 of PSA Administrative Order No. 1, series of 1993, death is a permanent disappearance of all evidence of life at any time after the live birth has taken place (post-natal cessation of vital functions without capability of resuscitation). It refers to the death of a human being and not to a loss of any part or organ thereof.
- By definition, a Certificate of Death is issued only in relation to the death of a person which is one of the requirements for acquisition of burial permits, as no remains can be buried without this certificate. In this case, a Certificate of Death can be issued with appropriate remarks "For Burial Purposes Only"

Special circumstance - Waiving of death certificate

- Death due to dangerous communicable disease (that needs to be buried or cremated within twelve (12) hours)
- Request for immediate burial without embalming or viewing (due to religious beliefs, culture and tradition)
- Far flung or hard to reach location of the deceased (where the embalming facility is not available)
- For body parts, death certificate is not required (unless they are the actual remains of individuals who really died)

Certificate of Death for Amputated Part or Part of the Body

- It is important to remember that the Certificate of Death for amputated part or parts of the body is not registrable. The hospital or attendant at death shall accomplish three copies of the certificate and shall forward the same to the local civil registrar not for registrations but for statistical purposes and reference.
- For consistent implementation, all local civil registrars should confer or make understanding with local health officials, hospital attendants and other concerned persons in this locality. A handbook on medical certification about the cause of death of a person. It is a quick and easy reference for physicians especially our municipal health officers in accomplishing death certificates. It provides information on the correct and proper way of certifying causes of death and accomplishing the death certificate.

***Release of Human Remains**

- A release form shall be secured.
- Ethical considerations shall be considered in conferring with the bereaved families.
- Identified body must be turned-over to the claimant/s in an isolated releasing area.
- Media control must be observed.
- The LSWDO can assist the bereaved families in availing available benefits.
- No human remains shall be donated or given to any entity even if it is for medical or scientific purpose/s.

MODULE 5: **REPORTING MISSING PERSON**

Module Objectives

At the end of this session, participants will be able to:

1. Define Missing Persons;
2. Develop understanding in the process of reporting missing persons;
3. Explain salient information found in the missing person's form; and
4. Demonstrate proper process of interviewing relatives of victims.

MISSING PERSONS

Shall refer to any reported person residing, working, studying or sojourning in a community which is directly affected by a disaster, nowhere to be found thereafter and has not been heard of since the disaster.

ELEMENTS OF REPORTING MISSING PERSONS

Importance of Reporting Missing Person

- To inform or appraise the next-of-kin of the missing person.
- To reduce the stress/anxiety experienced by affected communities.
- To defuse rumors and validate received information.

Elements of Reporting Missing Person

- Actors involved in Reporting Missing Person
- Process Flow of Reporting Missing Person
- Missing Persons Form

Actors involved in Reporting Missing Person

- The PNP shall verify the identity of the reported missing persons from the records of its Warrant Section.
- The DSWD shall also verify the reported missing persons from its records of Centers/Residential Care Facilities.
- The PNP shall immediately inform the incident commander to initiate active search and rescue / retrieval and provide feedback.
- The LSWDO shall certify that the missing person is affected by the disaster.
- P/C/MSWDO to establish the local Social Welfare Inquiry Desks.
- P/C/MSWDO to ensure available or alternative sources of information.
- The validated list of missing persons presumed to be dead shall be submitted to the Local Chief Executive for approval to the RDRRMC for issuance of Certificate of Missing Person presumed to be dead during the disaster.
- The DSWD, DOH, and PRC, shall provide technical and resource augmentation.
- DOH shall ensure that the interventions are in accordance with IASC standards and guidelines.

WHAT FORM TO USE FOR INITIAL INTERVIEW OF NEXT-OF-KIN (NOK)?

PNP Memorandum Circular No. 2017-033 dated 01 June 2016

Guidelines on the Recording, Monitoring, and Investigation of Missing and Found Persons, and Identification of Human Remains

MDM Missing Person Form



National Disaster Risk Reduction and Management Council
DEPARTMENT OF THE INTERIOR AND LOCAL GOVERNMENT
Management of the Dead and Missing Persons



MISSING PERSON INFORMATION FORM

Missing person's name and unique number for this file: <small>(If name, give family name first followed by comma then other names) (Use unique number on associated files, photographs or stored objects.)</small>
Interviewer name:
Interviewer contact details:
Interviewee(s) name(s):
Relationship(s) to missing person:
Contact details of interviewee: Address: Telephone: Email:
Other contact person for missing person, if different from above: <small>(who to contact in case of news). Give name and contact details.</small>

*Adopted from the International Committee of the Red Cross
Management of the Dead Bodies after Disasters: A Field Manual for First Responders Second Edition*

Trigger for the use of the AM Form is: Once DVI Team has processed the body available for verification, the AM Form must be filled-out for more information available for a more comprehensive identification of the missing.

Interview Guidelines

- The place for the interview can be and should be far from the morgue. If an interview cannot be conducted at the home of the next-of-kin or friend, the preferred location is not anywhere near the public and/or the media, and should ensure that the individuals interviewed are provided with private and comfortable surroundings.
- If a time is set for an interview, the Team should be sure to arrive at the appointed time.
- Upon arriving at the interview, the leader of the Interview Team should introduce each team member to the relatives and friends present.
- The Interview Team should ensure that relatives and/or friends are willing to take part in the interview and that they are aware they may request for a break any time during the interview.
- Interviewers should ensure that they always refer to the missing person/potential victim in the present tense and not in the past tense.
- When requesting for specific information relating to the missing persons/potential victims, the interviewer should refrain from asking personal and intimate specific questions, but instead encourage the interviewee to answer general questions.
- The members of the interview team should make a consistent effort to answer any specific questions asked by interviewees immediately and to the best of their ability throughout the interview.
- When questions cannot be answered, interviewees should be informed that the information in question will be obtained, if possible, and provided to them at a later date. No question should be ignored.
- Officers should make sure to collect information and materials needed within one single visit if possible in order to avoid further disturbance... or "visits should be kept to a minimum". In case more than one visit is required, it should be carried out by the same team – for consistency.
- Be a good listener. Be attentive to what the interviewee says and how they are saying it.
- Stay calm. Realize that the interviewee is under a lot of stress and does not need any more pressure brought by someone who is hyperactive, excitable or anxious.
- Do not be intimidating. Eye contact is important and has varying impacts. For example, in casual conversations eye contact is sporadic. Maintaining continuous eye contact can make an interviewee feel uncomfortable and less likely to cooperate. Additionally, in some cultures, eye contact in conversation is avoided and casual glances are considered an insult.
- The tone of voice and word choice should not convey that you condone or condemn the actions of the missing or the interviewed persons. This includes condemning anyone for his or her actions or lack of action. For example, asking the interviewee a pointed question such as: "Why did you let them do that?". Do not treat anyone with disrespect nor be patronizing or condescending. It is not the responsibility of the interviewer to judge interviewees; such an attitude could lead the interviewee to doubt the interviewer's sincerity in using the information obtained to only find the subject.
- As an Interviewer for MDM, there should be a threshold for handling clients (e.g., bereaved relatives). Hence, a slide for DEBRIEFING the INTERVIEWER should be included. A "Time out" for the responder/ MCP representative doing the interview should be included as well.

MODULE 6

MANAGEMENT OF THE BEREAVED FAMILIES

Module Objectives

At the end of this session, participants will be able to:

1. Recognize how to provide initial MHPSS to bereaved families;
2. Demonstrate appropriate and sensitive attitude in dealing with bereaved families; and
3. Know the different programs and services for the bereaved families.

GENERAL POLICY

- Local Social Welfare and Development Offices is the lead in the overall management of the bereaved families in coordination with Local Health Offices on the provision of physiological, psychological, and social needs.
- The Department Social Welfare and Development and Department of Health and other cluster member agencies provide technical assistance and augmentation for medical, psychological and financial needs of the bereaved families.

Types of Problems

Social/Psychological Problems

- Pre-existing (pre-emergency) social problems
- Emergency-induced social problems
- Mental health problems
- Humanitarian aid-related problems

Some of the Key Facts

- Almost all people affected by emergencies will experience psychological distress, which for most people will improve over time.
- People with severe mental disorders are especially vulnerable during emergencies and need access to mental health care and other basic needs.
- Despite their tragic nature and adverse effects on mental health, emergencies have shown to be opportunities to build a sustainable mental health system for all people in need.

People at increased risk for problems

- Children
- Women
- Men
- Elderly People
- Extremely Poor People
- Internally Displaced Persons (IDP)
- People who have been exposed to extremely stressful events/traumas
- People in community with pre-existing disorders
- People in institutions
- People experiencing severes social stigma
- People a specific risk of human rights violations

Cluster System

A process to improve effectiveness of humanitarian response through: **Accountability, Responsibility, and Partnership (Coordination and Prioritization)**

Who are the Internally Displaced Persons

- Persons or groups who have been forced or oblige to flee or to leave their homes or places of habitual residence as a result of or in order to avoid the effects of:
 1. Armed conflict
 2. Situations of generalized violence
 3. Violation of human rights
 4. Disasters
- Who have not crossed an internationally recognized state border

What is Protection?

All activities aimed at ensuring **full respect for rights of the individual** in accordance with the letter and the essence of the relevant bodies of law (i.e. human rights law, humanitarian law and refugee law)

Internally Displaced Person Protection

Ensure the protection of all IDPs, that their best interest and welfare shall be paramount considerations in all actions concerning them.

Inter-Agency Standing Committee (IASC) Intervention Pyramid

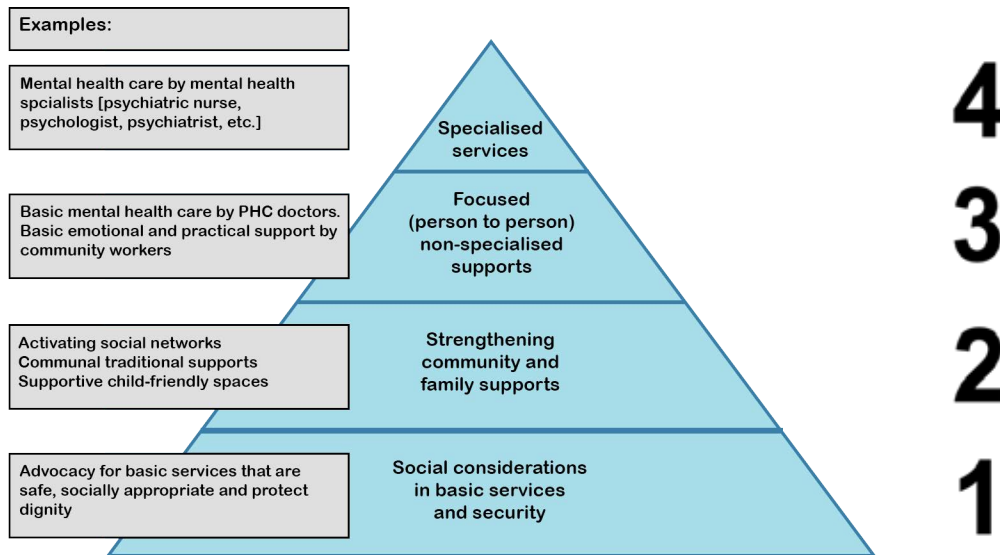

Mental Health Psychosocial Support Services

- To provide Psychological First Aid to the general population;
- To refer Psychiatric cases to appropriate Mental Health Facilities;
- To protect and promote well-being of responders; and
- To provide psychological interventions to survivors of sexual violence and vulnerable groups (OPs, PWDs, PWSNs, etc).

Psychological Processing

- It is a “package” of crisis intervention tactics.
- Is an intervention protocol developed specifically for dealing with traumatic events. It is a formal, highly structured and professionally recognized process for helping those involved in a critical incident to share their experiences, vent emotions, learn about stress reactions and symptoms and given referral for further help if required. It was developed to help manage traumatic experiences within organizations and communities.

Psychological First Aid

- Describes a humane, supportive response who is suffering and may need support.
- It aims to stabilize, reduce symptoms, and return the survivor to functional capacity in the aftermath of a critical incidents, it involves the following:
 - Providing practical care and support which does not intrude;
 - Helping people to address basic needs (food, water and information)
 - Listening to people and helping them to feel calm
 - Helping people connect to information, services, and social supports;
 - Protecting people from further harm

Guiding Principles

- Respect
- Safety
- Confidentiality
- Non-discrimination

Ethical Do's and Don't's

DO'S

- Be Honest and trustworthy
- Respect people's right to make their own decisions
- Be aware of and set aside your own biases and prejudices
- Make it clear to people that even if they refuse help now, they can still access help in the future
- Respect privacy and keep the person's story confidential, if this is appropriate
- Behave appropriately by considering the person's culture, age and gender

DON'TS

- Don't exploit your relationship as a helper
- Don't ask the person for any money or favor for helping them
- Don't make false promises or give false information
- Don't exaggerate your skills
- Don't force help on people, and don't be intrusive or pushy
- Don't pressure people to tell you their story
- Don't share the person's story with others
- Don't judge the person for their actions or feelings

Consider the following questions as you prepare to offer PFA in different cultures

Dress	<ul style="list-style-type: none">• Do I need to dress a certain way to be respectful?• Will impacted people be in need of certain clothing items to keep their dignity and customs?
Language	<ul style="list-style-type: none">• What is the customary way of greeting people in this culture?• What language do they speak?
Gender, Age and Power	<ul style="list-style-type: none">• Should affected women only be approached by women helpers?• Who may I approach? (e.g. head of the family or community?)
Touching and Behavior	<ul style="list-style-type: none">• What are the usual customs around touching people?• Is it all right to hold someone's hand or touch their shoulder?• Are there special things to consider in terms of behavior around the elderly, children, women, or others?
Beliefs and Religion	<ul style="list-style-type: none">• Who are the different ethnic and religious groups among the affected people?• What beliefs or practices are important to the people affected?• How might they understand or explain what has happened?

Management of the Bereaved Families

Physiological, social, psychosocial and medical needs, as well as assistance in the processing of benefit claims of the bereaved families shall be attended to by appropriate agencies.

- LSWDO - Lead agency in the overall management of the bereaved families
- Support:
 - DSWD, DOH, PRC, and development partners shall provide technical assistance and resource augmentation to LSWDO.

INSTITUTIONALIZATION

- Local Government Units
 - P/M/C Social Welfare and Development Office
 - P/M/C Health Offices
 - NGOs
- National and Regional Offices
 - DSWD
 - DOH
 - PRC
 - NGOs

Task/ Roles

P/M/C Social Welfare and Development Office shall provide the following:

- Financial Assistance;
- Transportation;
- Burial Assistance;
- Relief Assistance;
- Livelihood Assistance;
- Ensure the availability of Food, and Non-food items;
 - Family Food Packs
 - Family Kits
 - Hygiene Kits
 - Temporary Shelter
- Ensure availability of updated age/sex disaggregated data/masterlist of families; and
- Ensure availability of Trained personnel to conduct Psychological First Aid and Psychological Processing

National Government Offices shall provide the following:

- DSWD National and Regional Office shall provide augmentation support to the LSWDO on the following:
 - Financial Assistance
 - Transportation
 - Burial
 - Livelihood Assistance
- Ensure availability of Food and Non-food items
 - Family Food Packs
 - Family Kits
 - Hygiene Kits
 - Temporary Shelter
- Ensure availability of Trained personnel to conduct Psychological First Aid and Psychological Support Processing

ASSISTANCE AND SERVICES

Food and Non-Food Assistance

FAMILY FOOD PACKS

Composition:

- 6 kilos of rice
- 4 tin cans of sardines
- 4 tin cans of tuna flakes
- 4 tin cans of corned beef
- 6 sachets of instant coffee
- 6 sachets of powdered cereal drink.

Non-Food Items Assistance

Composition:

- 5 pieces spoons
- 5 pieces fork
- 5 pieces drinking glass
- 5 pieces plates
- 1 piece frying pan (kawali)
- 1 piece cooking pan (kaldero)
- 1 piece ladle

HYGIENE KIT

Composition:

- 5 pieces toothbrush
- 5 pieces toothpaste
- 5 bottle shampoo
- 2000 grams laundry bar soap
- 4 sanitary napkin
- 1 piece comb
- 1 piece disposable shaving razor
- 1 nail cutter
- 1 piece nail bathroom dipper

FAMILY KIT

Composition:

- 5 pieces bath towel
- 2 pieces ladies' panty
- 3 pieces girl's panty
- 2 pieces men's brief
- 3 pieces boy's brief
- 2 pieces sando bra, adults
- 3 pieces sando bra, girls
- 4 pieces adult's t-shirt
- 6 pieces children's t-shirt
- 4 pieces adult's shorts
- 6 pieces children's shorts
- 2 pieces adult's slipper
- 3 pieces children's slippers

SLEEPING KIT

Composition:

- 2 pieces blanket
- 1 piece sleeping mat
- 1 piece mosquito net
- 1 piece malong
- 1 piece pillow

FINANCIAL ASSISTANCE

Assistance to Individuals in Crisis Situation (AICS) is a provision of integrated services to individuals and families in crisis or difficult situation (either walk-in or referred) to enable them to meet their requirements for medical, transportation, legal, psychosocial, burial and other services in crisis situations

BURIAL ASSISTANCE

Assistance to shoulder funeral costs and related expenses, including, but not limited to cases of bringing home the bodies of their deceased member family in accordance with existing customary practices of the family especially among the indigenous people.

Requirements:

- Funeral Contract
- Death Certificate of the Deceased
- Barangay Certificate/ Indigency and any valid ID of the client
- Permit to transfer/ health permit (for transfer of cadaver)
- Referral letter (if applicable)

**Social Case Study Report may be required (subject to the assessment of the Social Worker)*

MEDICAL ASSISTANCE

Assistance to help shoulder hospitalization expenses, purchase of medicines, and other medical treatment or procedures and other medical expenses.

Requirements:

- Clinical Abstract/ Medical Certificate with signature and license number of attending physicians
- Hospital Bill, Prescription or Laboratory Request
- Barangay Certificate/ Indigency and any valid ID of the client
- Referral letter (if applicable)

TRANSPORTATION ASSISTANCE

Assistance for the payment of transportation (such as to purchase tickets to sea/land transport facilities) to enable them to return to their home provinces or to attend to emergency concerns such as death.

Requirements:

- Barangay Certificate/ Indigency and any valid ID of the client
- Police blotter (for victims of illegal recruitment, etc.)
- Referral letter (if applicable)

FINANCIAL ASSISTANCE

As support to early recovery and rehabilitation

Emergency Shelter Assistance

Enables affected families who opted not to be transferred to a resettlement site to purchase shelter materials in constructing or repairing partially or totally damaged houses destroyed as a result of national or human-induced disaster.

Emergency Cash Transfer (ECT)

The ECT is an adaptive strategy in bridging the gaps between immediate disaster relief, humanitarian response and early recovery support through the provision of unconditional cash to victims of disasters and emergency situations requiring DSWD interventions.

LIVELIHOOD ASSISTANCE

Capacity-building program for poor, vulnerable, marginalized households, and communities to help improve their socio-economic conditions.

MODALITY:

- Capital Seed Fund - serves as a start-up capital for the program participants.
- Cash for Building Livelihood Assets Fund - can be stipend equivalent to 75% of the prevailing DRMW for rendering work.
- Skills Training Fund - it is a capacity-building strategy to prepare program participants to better manage their chosen livelihood.
- Employment Facilitation Fund - includes: processing of employment requirements, payment of medical exam

OTHER ASSISTANCE

- Family/Peer Support System
- Social Welfare Inquiry Desk/Information Center
- Educational Assistance
- Legal Needs
- Psychiatric/Mental Health Services such as Psychological First Aid

MODULE 7

SYSTEM SUPPORT TO OPERATIONS

Module Objectives

At the end of this session, participants will be able to:

1. Identify general protocols in implementing the MDM;
2. Understand the importance of establishing systems support to operations of MDM; and
3. Identify succeeding steps in implementing MDM programs

Protocols

- Existing policies and guidelines on MDM shall be reviewed, enhanced, and harmonized with the overall policies and guidelines of the NDRRMC on the overall disaster management.
- Manual of Operations for MDM Standard Operating Procedures (SOPs) shall be developed to serve as reference for the crafting of own MDM SOP of each concerned agency/partners.
- New policies and guidelines shall be inclined with other essential components of the MDM as the need arises
- Dissemination and communication of every policy guidelines on MDM to all concerned units/ staff through various platforms and channels shall be done.
- Adoption of and compliance to policies and guidelines shall be tracked and integrated in the monitoring and evaluation.

Human Resources Development

- Formation of National and Regional MDM Rapid Deployment Mobile Teams (RDMT) shall be done comprising of members of multi-sectoral MDM teams and implementing partners
- MDM team members and volunteers shall undergo training program/s to enhance competencies (KAS) and performance.
- Training Plan and specific training modules shall be developed by a TWG comprising representatives from concerned agencies.
- Establishment of pool of trainers on the MDM training program should be implemented to passed on the training to the local level.
- A human resource development plan shall be prepared by all implementing partners
- Various benefits and welfare of responders shall also be administered and taken into consideration.

Reporting

- The affected LGUs shall submit initial reports with sufficient and needed information to the RDRRMC (copy furnished with the DOH-RO and DILG), within 12 hours of disaster emergency occurrence.
- Key indicators shall be determined by each implementing agency for MDM reporting.
- Every disaster, the lead cluster NDRRMC should properly document the MDM process and results. LGU and P/R/C/MDRRMC shall follow protocols on confidentiality of reports
- LDRRMC shall prepare and submit reports including identified and unidentified human remains, to the RDRRMC, through the documents submitted by the PNP, NBI DVI Teams, LCE, & LHO.
- The repository of information and reports should be the OCD, and these could be shared and accessed by concerned agencies.

Communication

- NDRRMC, the designated clearing house for information dissemination, should utilize its communication networks for information sharing at all levels in times of disasters.
- There should be an appointed information officer by the Incident Commander who will be ensuring media coverage, guided by MTRCB ethical standards.
- Information desk shall include the following menu messages: where families with missing persons will go after inquiry, process of DVI, & requirements to avail benefits and assistance.
- *The Public Information Agency (PIA) shall coordinate development of information communication plan on MDM through their Public Information Office (PIO) in partnership with other information partners.*

Information Management System

Databases shall be generated from all implementing partners which will be maintained by OCD, these include:

- Responders with corresponding area of expertise
- Training status of responders
- Accreditation status of volunteers
- Registry of accredited experts
- Inventory of equipment and infrastructures
- List of dead persons and missing persons

Logistics Management

- Identification of the basic package of logistics needed with corresponding specification shall be done by the implementing partner in charge with MDM.
- Inventory of logistics shall be administered at all levels. Stockpile prepositioning shall be implemented according to identified strategic areas.
- Each implementing partner shall develop a procurement plan for MDM based on standards and logistics requirements. This shall be integrated into their respective Emergency Preparedness and Response Plan.
- Management of donations of equipment and logistics shall be integrated in the overall policy on foreign donated goods.

Monitoring and Evaluation

- Joint monitoring shall be undertaken by the MDM cluster by DILG.
- Integrated tool shall be developed to monitor status, compliance and provision pre and post incident.
- Post incident evaluation shall be conducted every post emergency/disaster.

Research and Development

- Research agenda on MDM shall be crafted by the MDM Cluster.
- Resource mobilization shall be administered.
- Research results shall be disseminated to all concerned agencies and partners.

Financing

- Allocation of funds for MDM shall be made available by each implementing partner.
- NDRRMC shall exert all efforts to mobilize additional resources for MDM operations.
- LGUs, external, and internal agencies shall allocate funds in the annual budget for MDM operations.
- DILG and OCD, in consultation with COA, shall establish a flexible mechanism to fast track release and utilization of funds for MDM.

Responsibilities of Agencies/Offices

Networking and Collaboration

Agency/Office	Task/Responsibilities on MDM
DILG	Conduct semi-annual consultative meeting to partners and lead annual planning and joint M&E on MDM
MDM Cluster	Coordination with Logistics Cluster of National Disaster Response Plan for Transportation and Equipment
Local Chief Executive	Oversees the MDM Process. In extreme event cases, the Chairperson of Local DRRMC shall be the ICS Commander
NDRRMC	Establishment of check-in counters for all responders (local and foreign) at designated points of entry for screening, briefing and proper deployment

MODULE 8

REPORTORIAL REQUIREMENTS

Module Objectives

At the end of this session, participants will be able to:

1. Define key terms;
2. Identify the information flow;
3. Explain the process in Verification and Validation;
4. Identify reportorial requirements;
5. Determine the official source of information; and
6. Determine the publications and dissemination list of casualties

REPORTING DISASTER CASUALTIES

Why is it important to have a consolidated list of casualties?

- Credibility as government entities
- NDRRMC List of Casualties as one of requirements for GSIS/SSS benefits and other claims
- Data generated are being used for policy development and enhancement/revisions
- Submission of data for our international commitments (SFDRR, DRSF, SDG, etc.)

Definition of Terms

CASUALTIES – A person who died, got injured/ill or reported missing in relation to an emergency or disaster.

DISASTER – a serious disruption of the functioning of a community or a society involving widespread human, material, economic or environmental losses and impacts, which exceeds the ability of the affected community or society to cope using its own resources.

Processing of Reporting Casualties

- Local DRRM Councils shall report official and validated list of names of casualties to the Regional DRRMCs, including the age, sex, location of the incident, address, and details on the:
 - Dead – cause and date/time of death
 - Injured – brief description of the injury and medical services provided
 - Missing – date/time the person went missing
- The Regional DRRMCs shall consolidate all reports from Local DRRMCs and Regional DRRMC member-agencies shall submit the same to the National DRRM Operations Center.
- The LGU must submit to the NBI/PNP an updated list of missing persons. The LGU shall be responsible for updating the list of missing persons. (6.3.9 NDRRMC Memo Circular, s. 2016).
- The National DRRM Operations Center shall coordinate with the DILG and DOH to cross-validate the reports on dead persons.
- The National DRRM Operations Center (NDRRMOC) shall be the official source of casualties which will form part of the NDRRMC Situational Report.
- The NDRRMC Situational Report shall be disseminated and published to the Official NDRRMC Website and other available means of communication.

NDRRMOC SOPG 2021 Edition

The National and Regional MDM Clusters shall only submit reports upon activation by the Response Cluster. Any reported dead and missing not covered by the activation shall follow the usual reporting procedures

Reportorial Requirements

For Dead Persons

- Certificate of Identification (issued by PNP through CL or NBI)
- Death Certificate (issued by DOH, and Local Health Officer)

For Missing Persons

- Accomplished Incident Report Form (PNP); and/or
- MDM Standard Missing Persons' Form

Official Source of Information on Casualties

- For Dead Person:
 - PNP-FG, NBI, DILG, DOH, and LHO
- For Missing Persons
 - PNP and LGU

VERIFICATION AND VALIDATION

Verification

A process where information of a casualty in a disaster event is being confirmed thru investigation and official channels. This can only be proved thru a PNP Spot and/or Progress Reports and as reflected in the LDRRMO's Situational Report.

Validation

A process where the verified reported casualty in a disaster event is being confirmed thru a scientific method that determines the death of the casualty is directly and/or indirectly related to the disaster event. This can be proved thru the issuance of the Death Certificate.

Verification and Validation Process

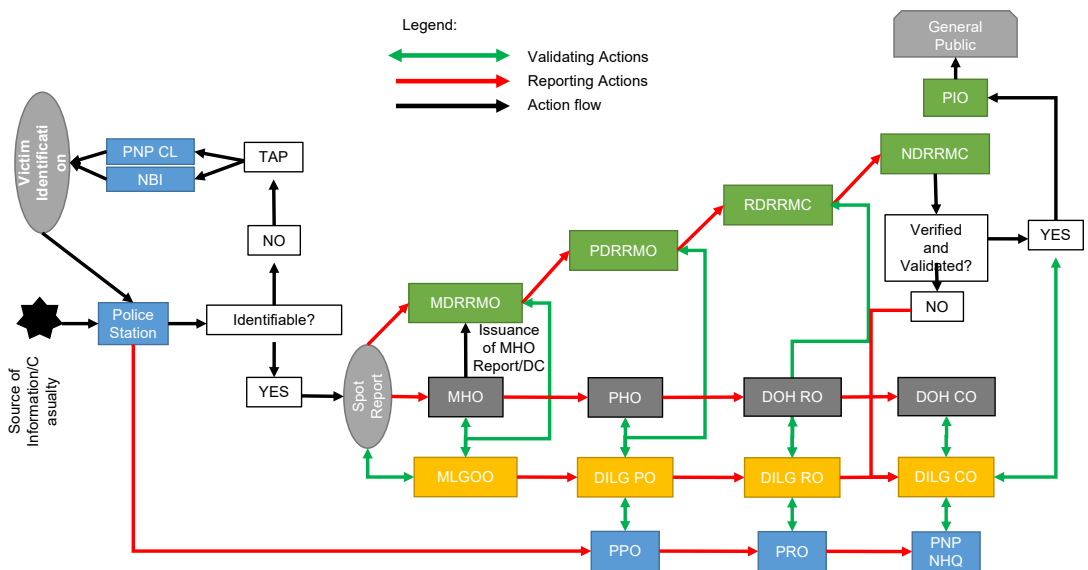

When can we say a casualty is VALIDATED?

DEAD

- Reportorial Requirements (Death Certificate, Certificate of Identification)
- Incident Report

MISSING

- Reportorial Requirements (Accomplished Incident Report Form, MDM Standard)

Missing Persons' Form

- Incident Report
- ONLY reported missing persons WITH IDENTITY shall be reflected in the NDRRMC SitRep. However, RDRRMCs may still reflect the number of missing persons (w/o identity) with an intent only to provide advance information to the NDRRMOC. (NDRRMOC SOPG 2021 Edition, Guidelines in Reporting Disaster Incidents, page 46)

DISSEMINATION AND PUBLICATION OF THE OFFICIAL LIST OF CASUALTIES

- NDRRMC Website
- Situational Reports
- Press Conferences / Briefings will be facilitated by the NDRRMOC with PCOO.
- Only the NDRRMC Chairperson and/or NDRRMC Executive Director or designated Spokesperson are allowed to accommodate interviews and provide the official number of casualties.

MODULE 9

FIELD MANUAL

Module Objectives

At the end of this session, participants will be able to:

1. Understand the protocols, guidelines and procedures of MDM;
2. Identify the minimum requirements in implementing MDM at the local level; and
3. Describe the MDM Cluster in the spectrum of pre-, during and post-disaster.

PURPOSE OF MDM

- Policies, standards and guidelines;
- Recommended systems and procedures to be used to strengthen coordination and collaboration between and among partner agencies and stakeholders who take part in disaster response, in general, and MDM, in particular, to ensure timely and well- coordinated actions;
- Established coordination and collaboration with the Search, Rescue and retrieval (SRR) Cluster for organized search and retrieval;
- Operations and proper documentation, in support to MDM operations; and
- Resource-sharing mechanisms, among others.

SALIENT FEATURES

- Coordination and Collaboration
- Rapid Assessment, Verification and Validation
- Communication as an inherent aspect of Coordination
- Incident Command System
- Documentation and Reporting
- Monitoring

TRANSITIONING FROM DISASTER RESPONSE

This Field Manual also provides actions in transitioning from disaster response to early recovery, as identified by NDRRMC.

Expanded Coverage of Disaster Response and Early Recovery	MDM Field Manual
Pre-Impact Phase	<p>Assists the LGU in the development of disaster preparedness plan, response plan (including early recovery actions), and identifying the actions needed to implement a well-coordinated MDM operation.</p> <p>Actions during the pre-emergency or pre-disaster stage have been identified in this Manual. This manual ensures that LGUs are taking the correct path in preparing for and responding to every threat in their locality. systems that need to be established are also identified in this manual. MDM LISTO are progressive actions contingent on particular hazards in the locality.</p>
Impact Phase	<p>To ensure that the LGUs will be organized to address all phases of MDM in disaster response, this Manual outlines the actions identified in managing coordination with other Clusters (particularly the SRR Cluster), dead body management, final arrangements for the dead, management of missing persons, and necessary interventions for bereaved families.</p> <p>Considering the tiered response from all concerned agencies, the LGUs are expected to take on the primary responsibility as disaster first responders.</p>
Post-Impact	<p>One of the most difficult decisions of the MDM team is identifying the start of the early recovery phase. While most of the indicators of early recovery can be identified by the return to normalcy of the basic services, the bereaved families are bearing the after-effects of loss which may lead to long-term grief.</p> <p>This field manual identifies the social needs of the bereaved families, which includes support systems, educational assistance, legal support, and other special needs such as psychosocial and mental health services.</p>

INTENDED USERS

- Both Resource Persons for, and Facilitators of, MDM trainings, as a technical reference;
- Practitioners of MDM during emergencies and disasters;
- Local Chief Executives, officers and staff of local DRRM offices, local social welfare and development offices, local health offices; and
- Other stakeholders in the practice of MDM.

L – Level-off

! – Institutionalize

S – Scale

T – Train

O – Organize and Equip

LEVEL-OFF

Calls upon all the key-players and discusses the proposed agenda to further strengthen and support the MDM Operations on the LGU.

INSTITUTIONALIZE

REVIEW and REVISE all the existing response plans (as needed):

- Local Disaster Risk Reduction and Management Plan (LDRRMP)
- Contingency Plan (hazard-specific)
- Search and Rescue Plan
- Search and Retrieval Plan (indicating proper equipment, personal protection, collection points, morgues, temporary burial sites, tags and markers)
- MDM Action Plan
- Enter into a MEMORANDUM OF AGREEMENT with funeral service providers, mortuary associations and other stakeholders, in order to augment the resources of the LGU.

SCALE

- Detect or determine when and where disasters can or will happen, based on geohazard maps, warnings, notices and updates from DOST- PAGASA, DOST-PHIVOLCS, DENR-MGB, DOH, PNP, AFP, BFP and PCG.
- Collect vital and relevant data to support the MDM Operations.
- Identify and designate MDM facilities within your locality.
- Forge partnerships with funeral service providers and similar organizations within your own, and nearby, localities.

TRAIN

Conduct training, or enroll your MDM team members to relevant MDM and other critical training.

ORGANIZE AND EQUIP

The MDM team needs to be organized: it should have a clear structure where all the functions are well-defined and properly assigned to each member. Tasking will be dependent on the various types of scenarios that will be encountered on the ground. The team must always be equipped with the appropriate PPEs, other equipment to be used during the operations, and the materials and equipment necessary for the documentation needs.

Organizing a Local MDM Team

There shall be an established and trained MDM team at every locality. The MDM Teams must always be ready to respond, regardless of the scale and complexity of the emergency or disaster.

During incident management at the local level, MDM teams shall be attached or assigned under the Operations Section Chief of the Incident Management Team. An MDM component shall join the SRR team, specifically to provide technical advice in the retrieval procedures, ensure proper documentation of the retrieval of dead bodies and body parts, and assess the necessary MDM resources that must subsequently be deployed.

Complementing the roles and responsibilities of the National Government Agencies, the Local Government Units must establish a separate MDM Team composed of the following:

Position	Responsibilities
MDM Group Supervisor	<ul style="list-style-type: none"> □ Directs execution of all actions related to MDM
Disaster Victim Identification Task Force	<ul style="list-style-type: none"> □ Leads the Disaster Victim Identification □ Determines the most appropriate method of identification □ Joins with the Search and Retrieval Team □ Prepares the list and actual number of processed human remains, classified as identified and unidentified. □ Collects, documents, and reports the post-mortem data. □ Coordinates with other MDM sub-clusters
Final Disposition of the Dead Task Force	<ul style="list-style-type: none"> □ Coordinates with other MDM sub-clusters □ Processes the burial and other related documents for purposes of proper disposal of identified and unidentified human remains or dead bodies □ Provides the list of claimed and unclaimed identified dead bodies. □ Facilitates the disposal and/or exhumation of human remains. □ Identifies legal issue/s encountered, recommends and coordinates with other stakeholders for the appropriate legal remedy.
Management of Missing Persons Task Force	<ul style="list-style-type: none"> □ Collects, documents, and reports the names, physical characteristics and other ante-mortem information of a reported missing person. □ Uses the Checklist for Absent/Missing Person Form (PNP Memorandum Circular Number 2016-033 dated June 1, 2016) in collecting and documenting reported missing persons. Uses, as applicable, the INTERPOL Ante - Mortem (AM) Form, in the case of reported missing foreign nationals. □ Issues the Certificate of Missing Person immediately after proper verification has been completed. □ Coordinates with other MDM sub-clusters.
Management of the Bereaved Families Task Force	<ul style="list-style-type: none"> □ Coordinates with other MDM sub-clusters. □ Establishes the relationship between families and the dead, and reported missing persons, based on the endorsements from either the Management of Missing Persons Task Force or Final Disposition of the Dead Task Force. □ Provides the necessary psychological, physiological, and social interventions to the bereaved families.

Components of Management of the Dead and Missing Persons

This Field Manual has five (5) components with its corresponding reference boxes to provide and guide all MDM practitioners on the process flow on the MDM Operations. The following components are:

- COMPONENT I: MDM AND SRR
- COMPONENT II: DEAD BODY MANAGEMENT
- COMPONENT III: FINAL ARRANGEMENT OF THE DEAD
- COMPONENT IV: MANAGEMENT OF MISSING PERSONS
- COMPONENT V: MANAGEMENT OF BEREAVED FAMILIES

Management of the Dead Persons due to Dangerous Communicable Diseases

This Field Manual also includes the process for the management of dead persons due to dangerous communicable diseases.

MANAGEMENT OF THE DEAD AND MISSING PERSONS

**TRAINING
GUIDE**